

## XGN20-12L/630-25 XGN20RL/125-31.5 Indoors AC High Voltage SF6 Looped Ring Main Unit

### Introduction

XGN20-12L/630-25 and XGN20-12RL/125-31.5 indoor AC high voltage SF6 Ring Main Unit (hereafter "RMU" for short) is a new generation of metal enclosed switchgear with SF6 load switch as the main switch. The whole switchgear is air insulated, using sensor technology and latest relay protection components with a leading international design level.

XGN20-12V/1250-31.5 indoor AC high voltage vacuum circuit breaker Ring Main Unit is applied with vacuum circuit breaker as the main switch. With simple and compact structure, flexible and convenient operation, reliable and effective interlock, this kind of switchgear is mainly used for ring network power supply or radial power supply system with three phases rated frequency of 50-60Hz and rated voltage of 12kV, as the circuit control and protection device. It is especially suitable for power systems such as small secondary power distribution station, cabinet transformer substation, switching station, industrial and mining enterprises, city Communities, airports, hospitals, railways, tunnels, high-rise buildings. It could be used for providing safety, reliable automatic services for power supply station. Different places, different users, different technical schemes.

### Model specification

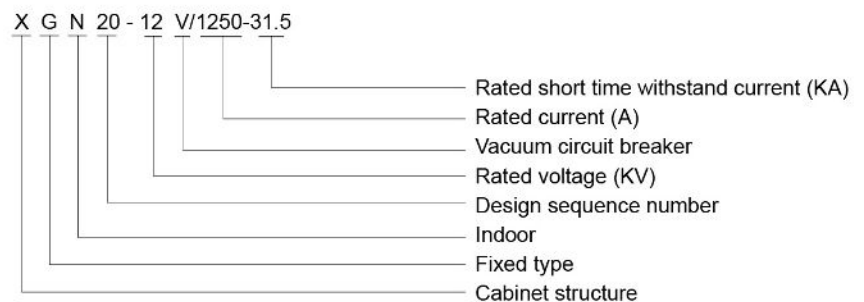
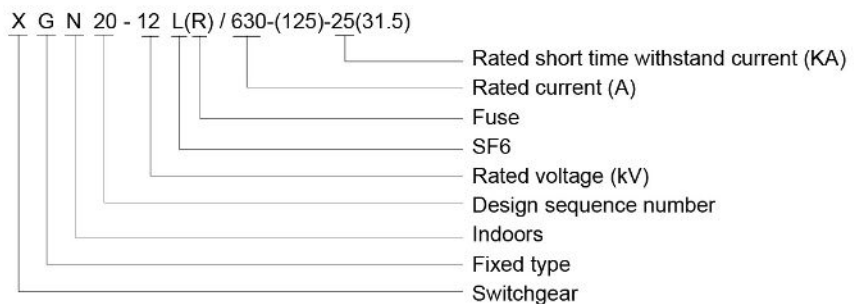

### Working environment

1. Height: less than 1000m;
2. Environment temperature: -25℃ ~+40℃ ;
3. Atmosphere relative humidity: daily average no more than 95%, monthly average no more than 90%.
4. No serious pollution in the surrounding atmosphere, such as dust, smoke, corrosive, combustible gas, gasoline salt liquid etc.
5. Earthquake intensity: 8.

## Main structure for looped network cabinet

RMU consists of busbar room, three position load switch room (or circuit breaker room), cable room, operation mechanism, interlock mechanism and low-voltage control room and measurement. Each cabinet is separated by steel plate to avoid accident spreading. The product complies with AC metal enclosed switchgear and control equipment referred to GB3906 3.6KV-40.5KV, and rated voltage 1KV-52KV AC metal enclosed switchgear and control equipment referred to IEC62271-200.

### 1 Busbar room

Busbar room is in the top of the switchgear in which the main busbars are connected together and through the whole switchgear. Main busbars are horizontally arranged which are easily to be extended.

### 2 Load switch room

There is a three-position load switch installed in this room. Its shell is made of epoxy resin with SF6 gas filled in as the arc extinction and insulation medium. There are two transparent hot-stamped plastic end caps on the operating shaft terminals. The contact status can be observed through the end caps. SF6 gas density meter or density meter with alarm can be installed as per customer requirement.

### 3 Cable room

The cable room is used to connecting cables. Single core or three-core cable can employ the simplest shielded cable head for connecting. Meanwhile, it can be equipped with arrester, current transformer, voltage transformer and lower earthing switch. In terms of standard designation, there is an observation window and safety interlock device. The bottom plate of the cable room is equipped with sealing cover and suitable cable clamps with mountings. The door on the bottom plate of the cable room is removable, which is easily for cable installation and remove.

### 4 Operation mechanism, interlock mechanism and low voltage control room

Low voltage control room with interlock also plays a role as a control panel. In the low voltage room, there are spring operation mechanism and interlock mechanism with location indicator, auxiliary contact, tripping coil, emergency tripping mechanism, and condenser charging indicator, key lock and manual operating device. In addition, control circuit, meter instruments and protective relay can be fixed in the room.

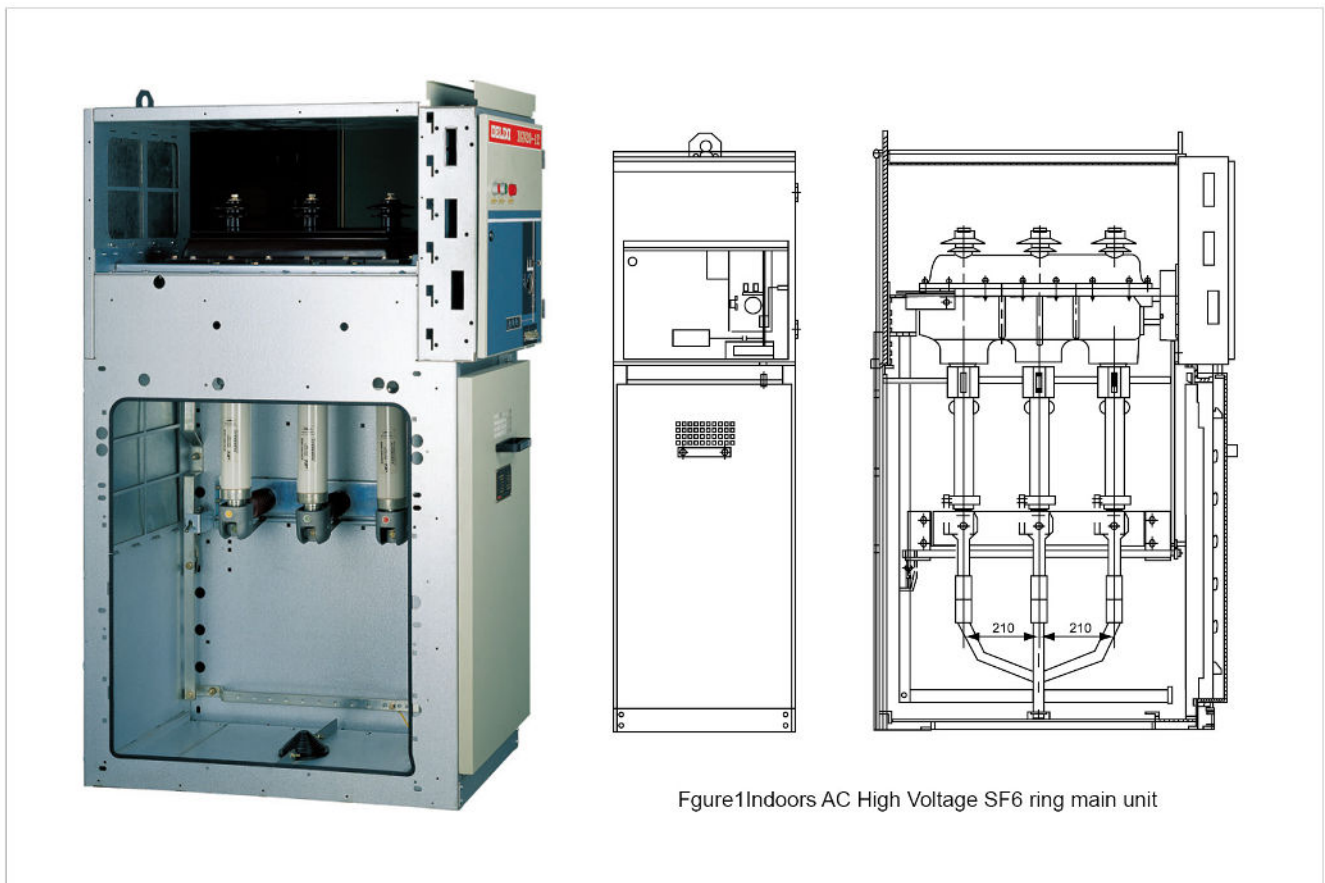

Figure1Indoors AC High Voltage SF6 ring main unit

## Technical parameters

### Main technical parameters

Description		Unit	Parameter	
Rated voltage		kV	12	
Rated frequency		Hz	50	
Rated		A	630	
Rated current of fuse			125	
Rated short time withstand current		kA	25	
Rated short time continuous time		s	2	
Rated short circuit peak current		kA	63	
Rated peak withstand current			63	
Rated load breaking current		A	630	
Rated transferring breaking current(with 125A fuse)			1700	
Rated breaking current of fuse (effective value)		kA	31.5	
Rated insulation level	1 min power frequency withstand voltage(effective value)	Alternative, relative	42	
		Fracture	48	
	Withstand voltage with thunder impact (peak value)	Alternative, relative	75	
		Fracture	85	
Secondary circuit 1 min power frequency withstand voltage			2	
IP			IP3X	
Center distance of three phases		mm	210 ± 2	
Dimension	Load switch cabinet		Width	375,500,750
			Depth	940
			Height	1635,1850
	Breaker cabinet		Height	450
			Width	750
			Depth	940
			Height	1850
Mechanic life of load switch			Times	Switch in/ switch out
		Switch out/Earthing		1000

## Main scheme of Looped network cabinet





Scheme number		01	02	03	04
Wire connecting drawing					
Purpose		Incoming	Incoming	Incoming	Incoming
Quantity					
Components models and descriptions	FLN48-12 SF6 load switch	1	1	1	1
	Spring operation frame	K	K	K	K
	Current mutual inductor LZZBJ9-10			3	3
	Lightening rod HY5WS				3
	Electric displayer DXN6-T5	1		1	1
Cabinet dimension	Width	375	375	375/500	500
	Depth	940	940	940	940
	Height	1635/1850	1635/1850	1635/1850	1635/1850

  

Scheme number		05	06	07	08
Wire connecting drawing					
Purpose		Outgoing	Outgoing	PT	PT
Quantity					
Components models and descriptions	FLN48-12 SF6 load switch	1	1	1	1
	Spring operation frame	A	A	K	K
	Voltage mutual inductor JDZ			2	2
	Fuse SDL □ J	3	3		
	Electric displayer DXN6-T5	1		1	
	Earthing switch EF-210	1	1		
	Fuse XRNP			3	3
Cabinet dimension	Width	375/500	375/500	500/750	500/750
	Depth	940	940	940	940
	Height	1635/1850	1635/1850	1635/1850	1635/1850

Scheme number		09	10	11	12
Wire connecting drawing					
Purpose		Incoming	Connection	PT	Connection
		Quantity			
Components models and descriptions	FLN48-12 SF6 load switch				1
	Spring operation frame				K
	Current mutual inductor LZJB9-10			3	
	Voltage mutual inductor JDZ			2	
	Fuse Plug XRNP			3	
	Monitor DXN6-T5			1	1
	Bush	3	3	6	
Cabinet dimension	Width	375	375	750	375/500
	Depth	940	940	940	940
	Height	1635/1850	1635/1850	1635/1850	1635/1850

Scheme number		13	14	15	16
Wire connecting drawing					
Purpose		Connection	Connection	PT	PT
		Quantity			
Components models and descriptions	FLN48-12 SF6 load switch		1		
	Spring operation frame		k		
	Current mutual inductor LZJB9-10			2	2
	Voltage mutual inductor REL			2	2
	Fuse Plug XRNP			3	3
	Monitor DXN6-T5		1	1	1
	Bush	3			
Cabinet dimension	Width	375	375/500	500/750	500/750
	Depth	940	940	940	940
	Height	1635/1850	1635/1850	1635/1850	1635/1850

Scheme number		17	18	19	20
Wire connecting drawing					
Purpose		Connection	Incoming	Incoming	Incoming
		Quantity			
Components models and descriptions	GN38-12switch disconnecter	1	1	1	1
	Current mutual inductor LZB2-12	2	2	2	2
	Voltage mutual inductor JDZ10-10			2	
	Fuse Plug XRNP			3	
	Monitor DXN-T5	1	1	1	1
	Earthing switch JN15-12				1
	Lightening rod HY5WS		3		
	Vacuum circuit breaker	1	1	1	1
Cabinet dimension	Width	750	750	750	750
	Depth	940	940	940	940
	Height	1850	1850	1850	1850

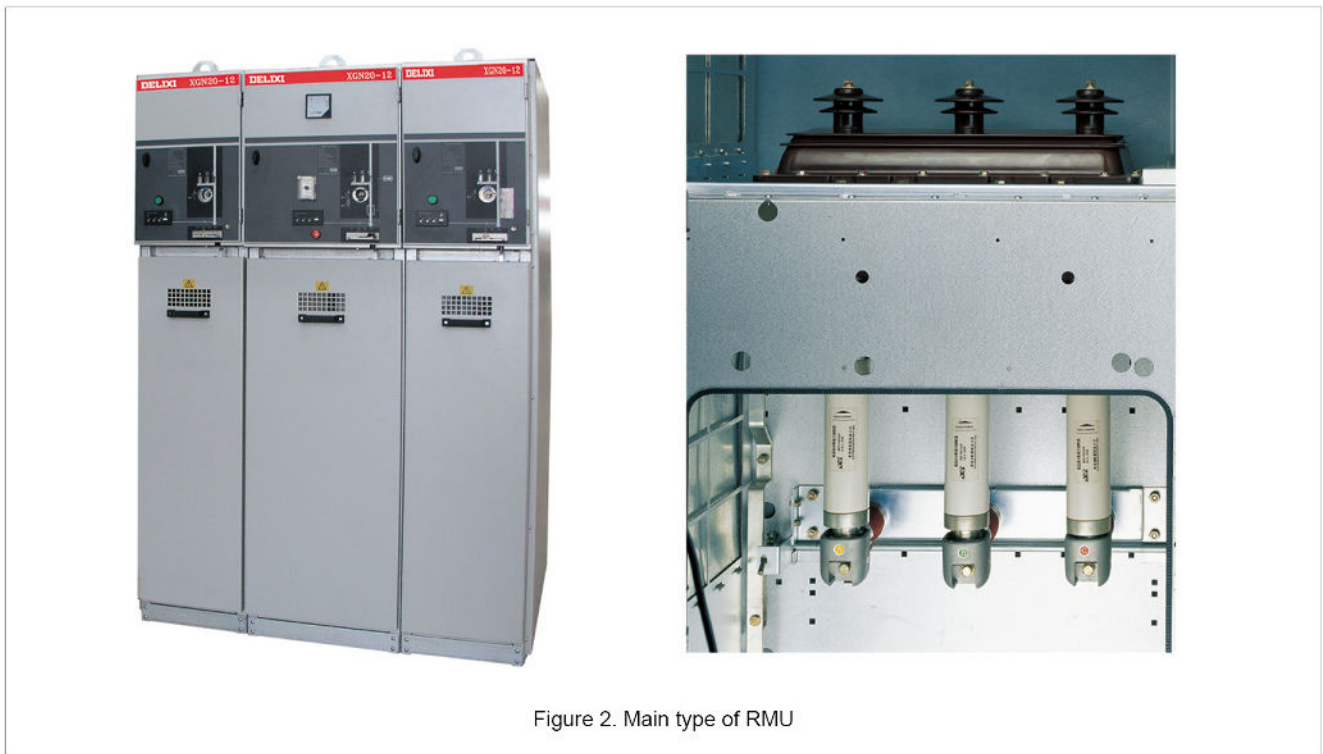

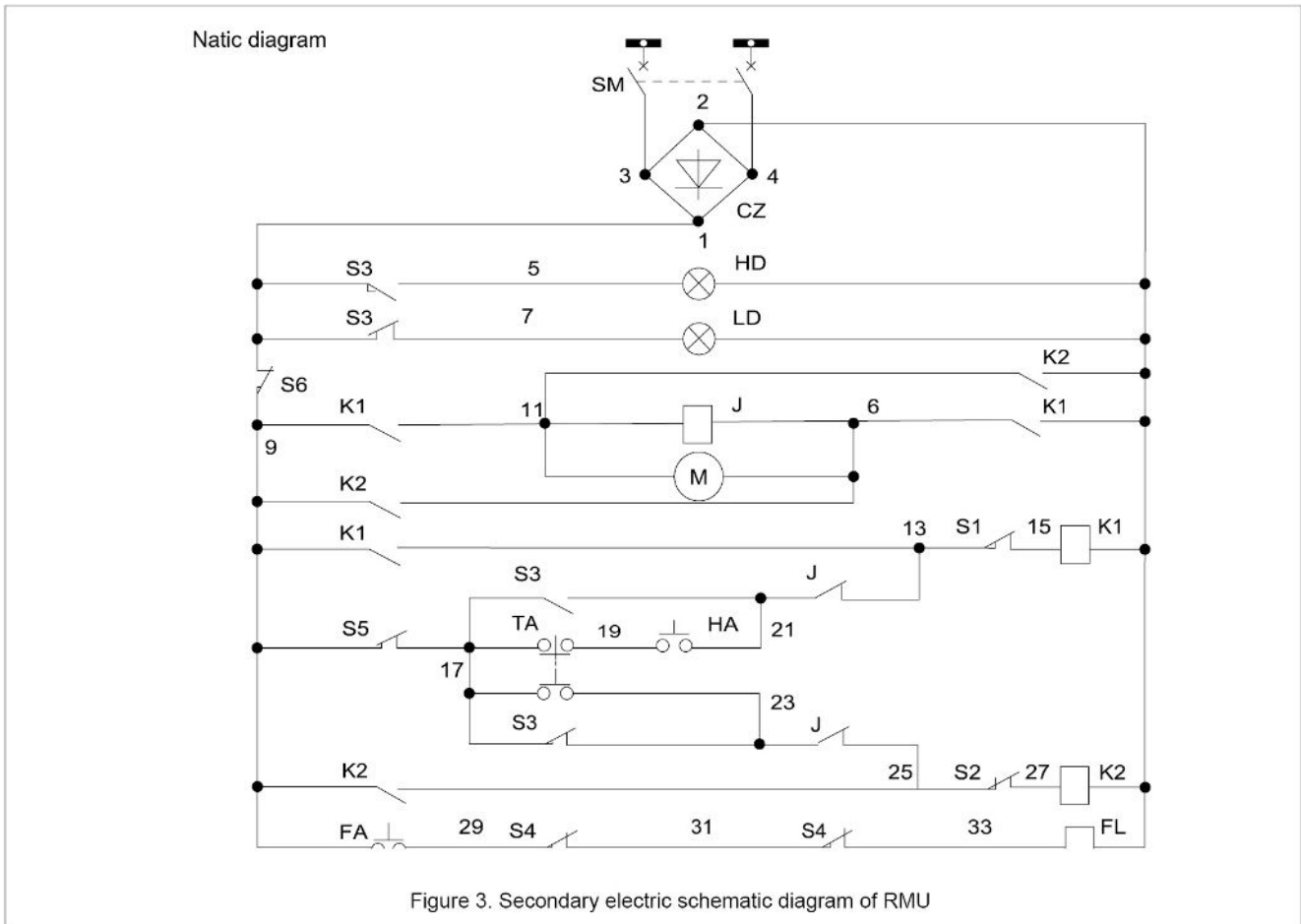

LD	Breaking switch indicator	AD16-22B DC220V	1	Green
FA	Shunt trip button	XB2-EA125	1	Black
FL	Shunt trip coil	DC220V	1	
HD	Closing switch indicator	AD16-22B DC220V	1	Red
S6	Stroke switch	LXW-18-11MB	1	Lock in (with mechanism)
S5	Stroke switch	LXW22-11	1	Earthing place(with mechanism)
S3,S4	Stroke switch	LXW22-11	1	Switch in & out location (with mechanism)
S1,S2	Stroke switch	LXW-18-11MB	1	Together or separate stop (with mechanism)
M	Electromotor	DC220	1	With mechanism
CZ	Commutated device	KBPC3510	1	
J	Center relay	DZ47-4Z DC220	1	
K1,K2	DC contractors	BC6-31-00 DC220	2	
SM	Air switch	C65AD-4A/2P	1	
TA	Breaking button	XB2-EA145	1	Red
HA	Closing button	XB2-EA135	1	Green

## Basic dimensions of RMU

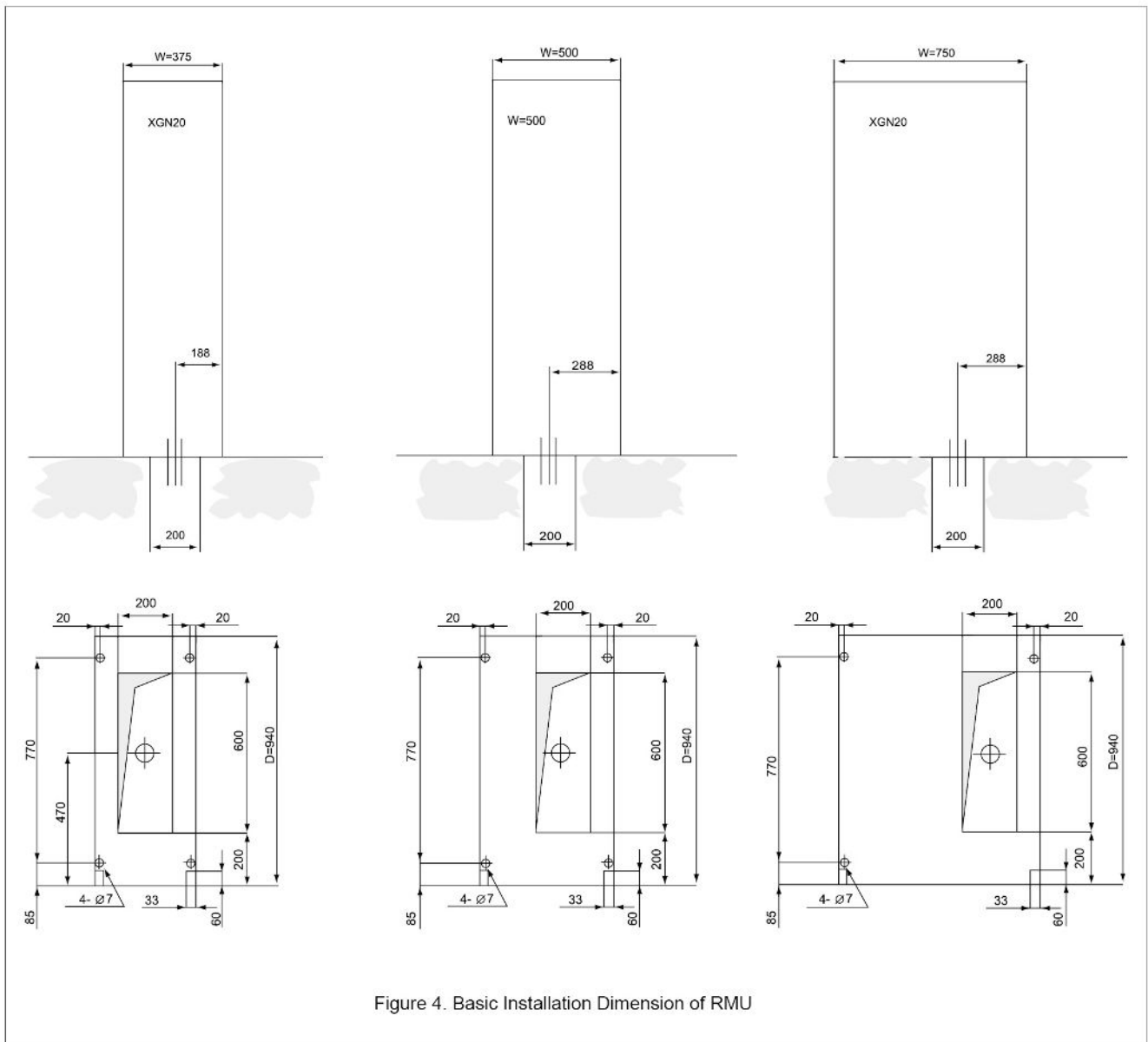

Figure 4. Basic Installation Dimension of RMU

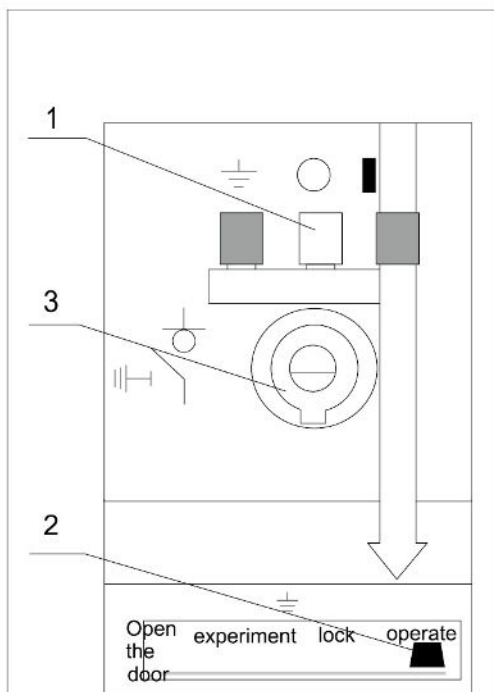

Figure 5

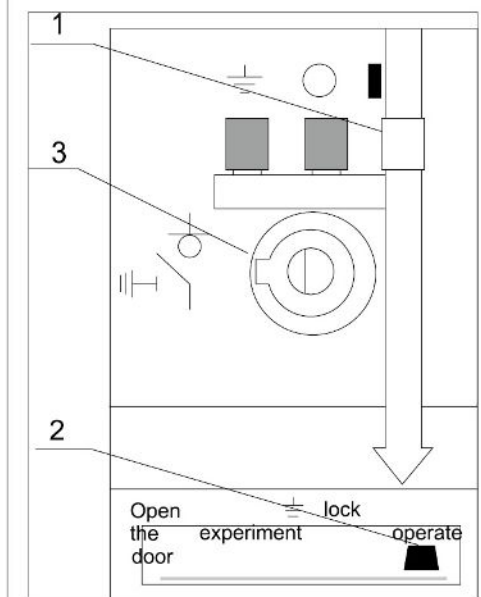

Figure 6

## The use and operation

### The operation mechanism of the operating sequence

#### Manual operation of load switch

##### 1. Closing of load switch

Place the load switch location indicator to the site shown in Figure5 (1). The selector is placed on the operation site, shown in Figure5 (2). Check the shaft ratchet which should be downwards as indicated in Figure5 (3). When the fuse is burned out or the electric operation makes the switch open, the slot is leftwards, operation handle need to be inserted to the hole, turn the slot anticlockwise to downwards (with "crack" sound). Insert the operation handle to the slot, then make the guidance key match the slot shafting, turn it with approximately 80 degrees clockwise until it is closed. If the switchgear is equipped with double-spring mechanism, when turn to the terminal point, increase strength to turn it until the switch is closed at one time.

##### 2. Breaking of load switch

Place the load switch location indicator to the site shown in Figure6 (1), selector at site shown in Figure6 (2). Check the shaft which should be at site Figure6 (3). Insert the operation handle to the slot, then make the guidance key match the slot shafting, turn it with approximately 80 degrees clockwise until it is breaking.

##### 3. Load switch operation site to earthing site

Place the load switch location indicator to the site shown in the Figure7 (1). The selector is placed on the test site, shown in Figure7 (2). Check the shaft ratchet which should be downwards as indicated in Figure7 (3). Insert the operation handle to the slot, then make the guidance key match the slot shafting, turn it with approximately 80 degrees clockwise until it is on the earthing site.

##### 4. Load switch earthing site to breaking site

Place the load switch location indicator to the earthing site, shown in Figure8 (1). The selector is placed on the test site, shown in Figure8 (2). Check the shaft ratchet which should be vertical as indicated in Figure8 (3). Insert the operation handle to the slot, then make the guidance key match the slot shafting, turn it with approximately 80 degrees clockwise until it is breaking.

#### Load switch motor operated

Operation mechanism could be operated locally or remote operation, to achieve switch closing or breaking.

### Door open of the cable room

1. When the switch is at earthing site and the selector is at door opening site, the door of cable room can be open and removed.

Hint:

Open the door → hold the handle and lift the door → remove the door.

Close the door → lift the door to the doorsill → close the door → push the door downwards

2. Open and close the door of operation mechanism room

Turn the handle clockwise, the door opens. On the contrary, turn the handle anticlockwise, the door closes.

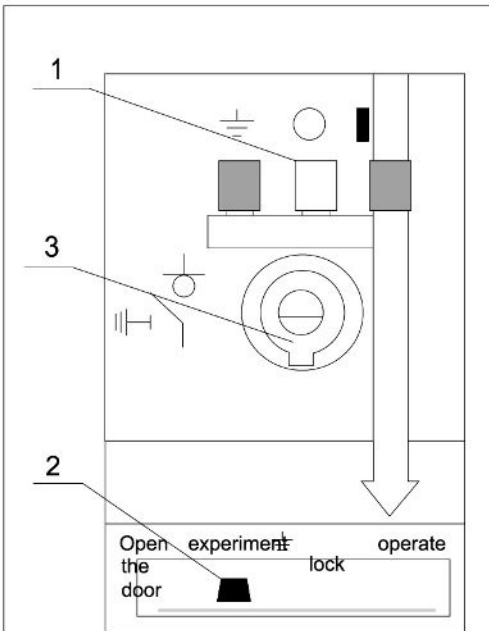

Figure 7

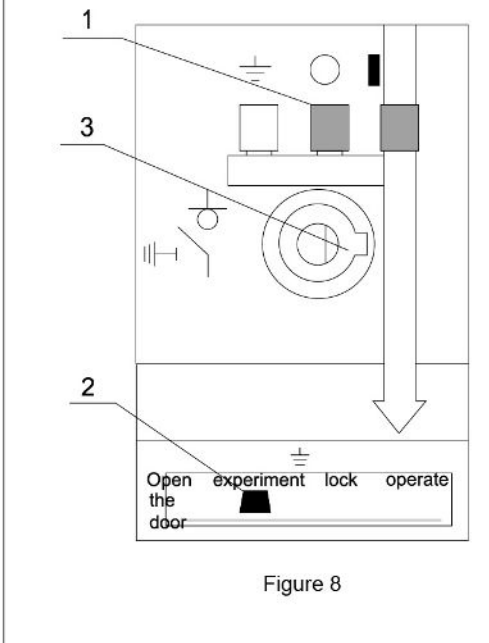

Figure 8

## Maintenance

Generally, the warranty of switchgear is three years. Single-spring and double-spring operation mechanism of the load switch is no need to maintain or add any lubricating fluid. Relay device needs to be verified according to manufacturer requirement before putting into operation.

Maintenance measurement details is shown as below,

1. Fasten all electric connections (main busbar, switch, cable, meters etc.) according to the requirements of installation and usage manual.
2. Clean all components by vacuum cleaner (such as load switch, circuit switch, switch disconnecter, electric motor etc.), and check the appearance.
3. switch on/off all switches including earthing switch for one time.
4. Connect to supporting control power (no remote signal), operate once according to electric sequence
5. Clean busbar room and cable room. Open the upper part of the cabinet, clean insulation part and busbars using clean soft cloth. For thick dust of sticky dirt, use cloth with little alkaline detergent to clean it first, and then use clean cloth with clean water to wash it. Finally, use dry cloth to wipe the surface to dry. Use the same way to clean cable room (such as the bottom of load switch, mutual inductor, busbars and circuit switch etc.)

Note: no chloroform, carbon tetrachloride (CCl<sub>4</sub>) or variety alcohols to be used when cleaning.

Acceptance requirements (AR): all parts are in good condition, no clear discharge mark or damage, no obvious overheated phenomenon on connecting surface. Once any unqualified parts are found, they should be replaced.

## Order information

Clients need to provide below technical information when ordering,

1. Main circuit scheme number, main circuit scheme, arrangement drawing, layout drawing.
2. Switchgear secondary circuit schematic diagram.
3. Model, specification and quantity for all components in switchgear.
4. Material, specification and quantity for main busbar, branch busbar in switchgear.
5. It needs to be indicated if low voltage cabinet is needed.
6. Electric equipments summary list.
7. Indicate the environment if the switchgear is used in special conditions.
8. If other or exceeded attachments, spare parts are needed, provide categories and numbers.