



SIVACON 8PT Low Voltage Switchgear Introduction



Siemens Ltd., China

A&D Group.

LV DM

SIVACON

SIVACON 8PT Introduction

Background Knowledge Introduction

8PT Brief Introduction



- ▶ Developed in Germany and produced by global partners;
- ▶ Complete type test;
- ▶ Flexible application scheme;
- ▶ Rated current of horizontal bus to 7400A;
- ▶ SIMARIS SIVACON software regulates the production of partners.

低压
控制与配电
动力配电中心

Low Voltage
Power Control
and Distribution
Power Distribution Center

www.siemens.com/lowvoltage

Background
Knowledge
Introduction



SIVACON 8PT Introduction

SIVACON 8PT Product General Introduction



低压
控制与配电
动力配电中心

Low Voltage
Power Control
and Distribution
Power Distribution Center

www.siemens.com/lowvoltage

General

Application Range

Power Center

I_n to 7400 A
 I_{cw} to 150 kA
 I_{pk} to 375 kA

Main Distribution Cabinet

I_n to 4000 A
 I_{cw} to 100 kA
 I_{pk} to 250 kA

Branch Main Distribution Cabinet

I_n to 3200 A
 I_{cw} to 80 kA
 I_{pk} to 200 kA

Motor Center

I_n to 3200 A
 I_{cw} to 80 kA
 I_{pk} to 200 kA

Load

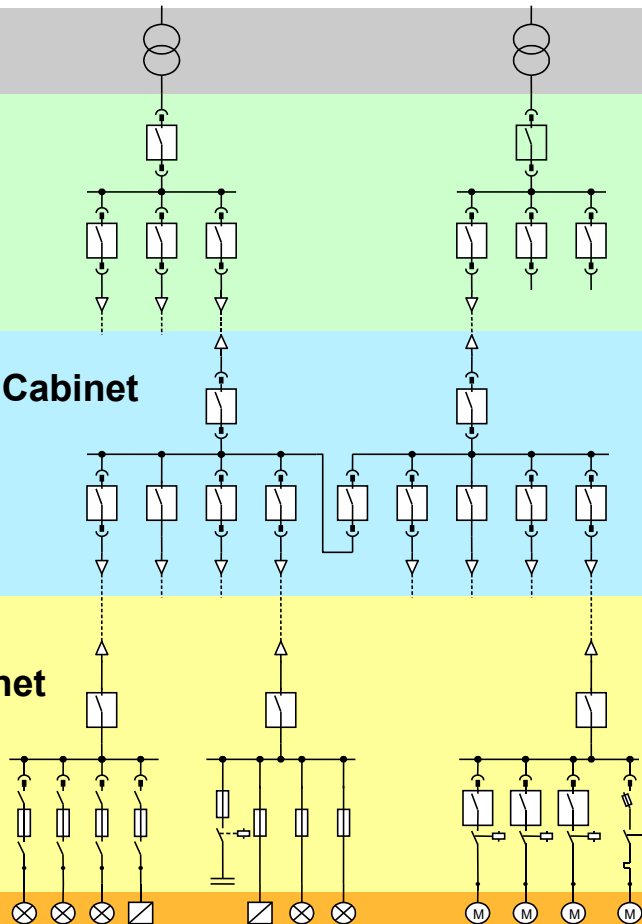

SIVACON 8PT Introduction

SIVACON 8PT product overview



低压
控制与配电
动力配电中心

Low Voltage
Power Control
and Distribution
Power Distribution Center

www.siemens.com/lowvoltage

Product overview

Standards and specifications

Standards and specifications	Fully type-tested Low Voltage switchgear (TTA)	IEC 60439-1 DIN EN 60439-1 (VDE 660 part 500) DIN VDE 0106 part 100
	Internal fault condition The arc test of	IEC 61641, VDE 0660 Part 500, Add 2
	Electrical clearance and creepage distance	DIN EN 60439-1 (VDE 0660 part 500)
	Rated insulation voltage (Ui)	1000 V
Rated operating voltage (Ue)	to 690 V	



SIVACON 8PT Introduction

SIVACON 8PT product overview



低压
控制与配电
动力配电中心

Low Voltage
Power Control
and Distribution
Power Distribution Center

www.siemens.com/lowvoltage

Product overview

Full type test (TTA) and supplementary test



Temperature rise limit, dielectric properties



Short-circuit breaking



Short-circuit withstand strength



Protection circuit effectiveness and short-circuit withstand strength



Electrical clearance and creepage distance



Mechanical operation, protection class, insulation, protection measures, insulation resistance, etc



Arc test under internal fault condition



Seismic test



SIVACON 8PT Introduction

SIVACON 8PT product overview



低压
控制与配电
动力配电中心

Low Voltage
Power Control
and Distribution
Power Distribution Center

Technical parameter

Electrical clearance and creepage distance	Rated impulse withstand voltage (U_{imp})	8kV
	Overvoltage class	III
	Pollution level	3
Rated insulation voltage (U_i)		1000 V
Rated operating voltage (U_e)		to 690 V
Internal partition	Form 1 to form 4	IEC 60439-1, Paragraph 7.7 , 60439-1
Surface treatment	Support structure shell door	Galvanizing/Powder spraying/painting Galvanizing/Powder spraying/painting Powder spraying/painting
Class of protection		IP 30 to IP 54
Overall dimension	highth:	2200, 2600mm
	width:	400, 600, 800, 1000, 1200, 1600 mm
	depth:	600, 800, 1000 ,1200 mm

1/7



SIVACON 8PT Introduction

SIVACON 8PT Product design (Skeleton and shell)



低压
控制与配电
动力配电中心

Low Voltage
Power Control
and Distribution
Power Distribution Center

www.siemens.com/lowvoltage

Product design

Modular structure

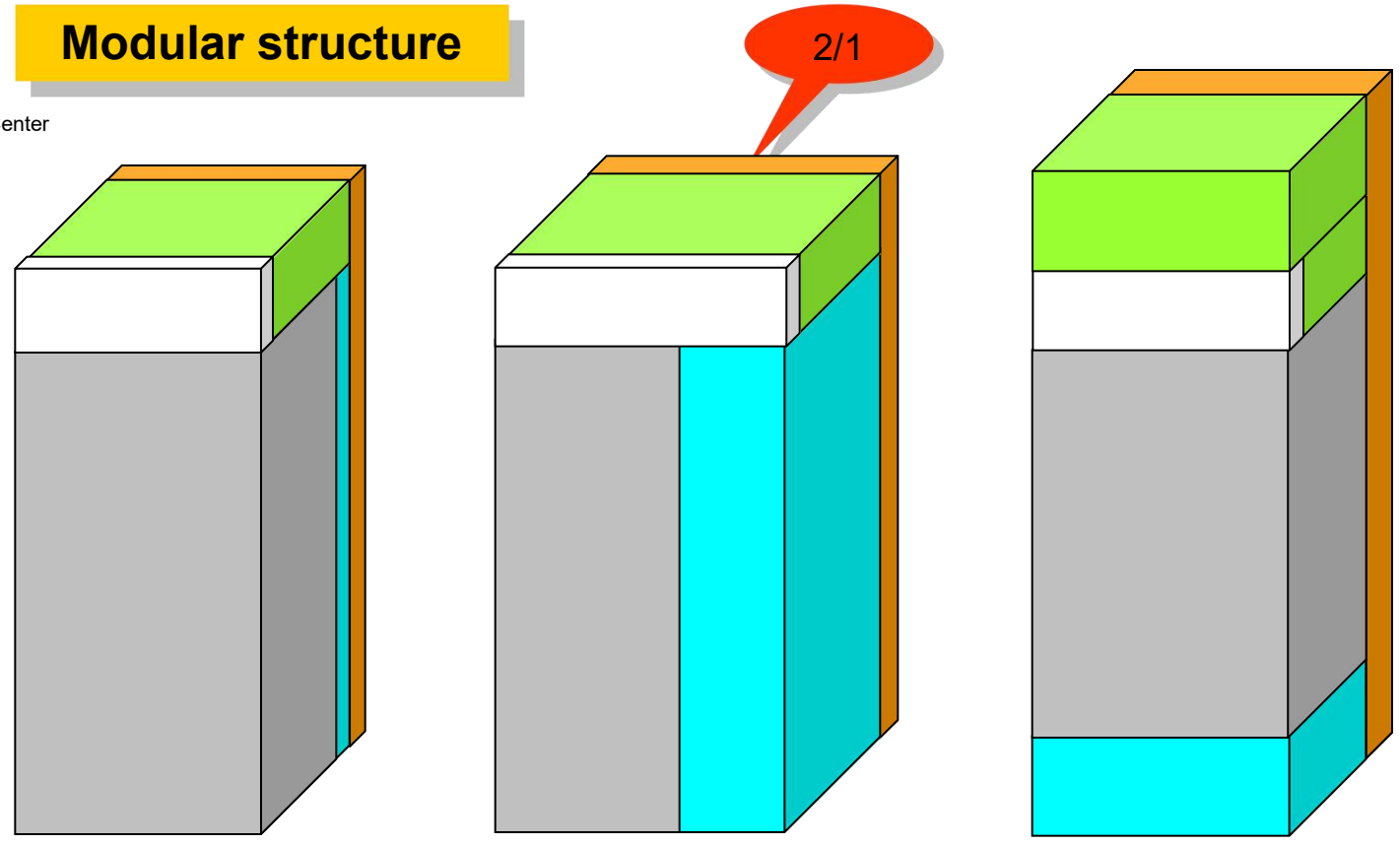

- Component compartment
- Horizontal bus compartment
- Cable connection compartment
- Upper cable connects compartment (Optional)

Transverse connection compartment (optional)



SIVACON 8PT Introduction

SIVACON 8PT Product design (Skeleton and shell)



低压
控制与配电
动力配电中心

Low Voltage
Power Control
and Distribution
Power Distribution Center

www.siemens.com/lowvoltage

**Extremely rigid
column**

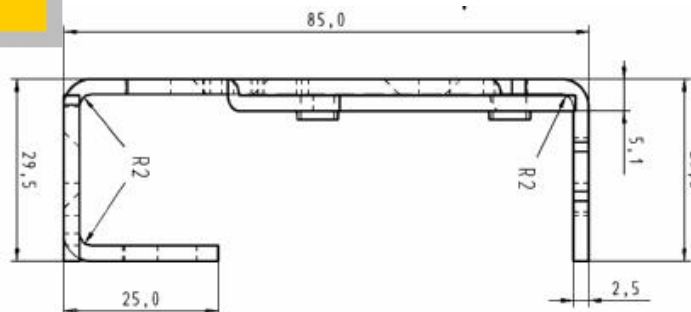

Product design

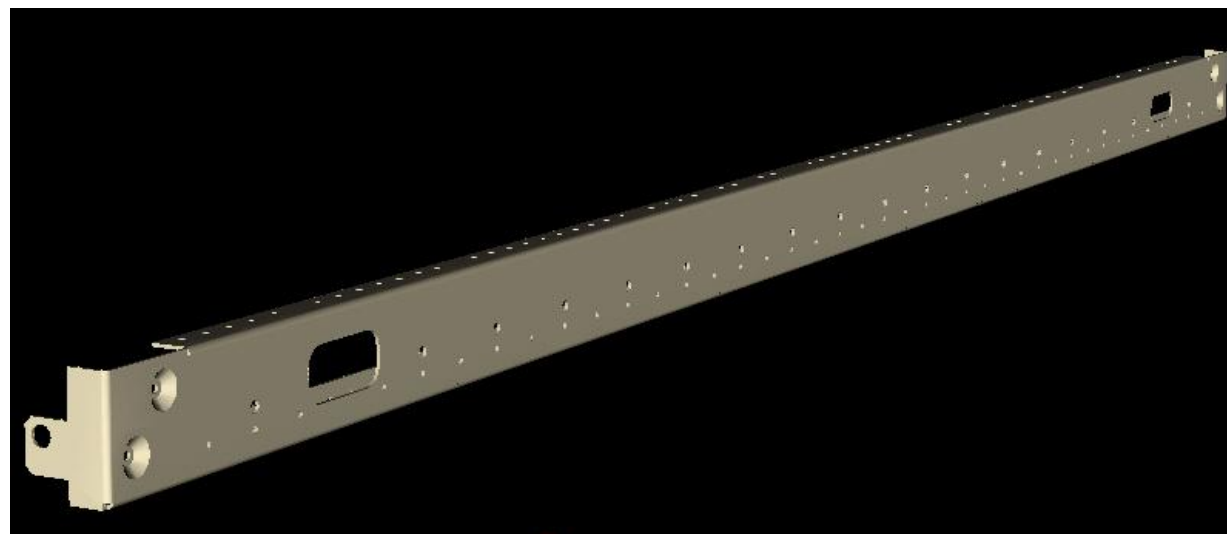

SIVACON 8PT Introduction

SIVACON 8PT Product design (Skeleton and shell)



低压
控制与配电
动力配电中心

Low Voltage
Power Control
and Distribution
Power Distribution Center

www.siemens.com/lowvoltage

Product design

Door locks and hinges



Door locks are available in a variety of options

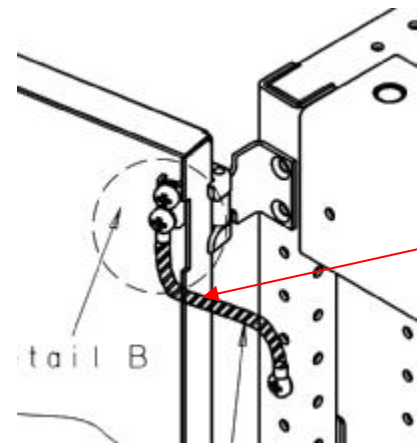
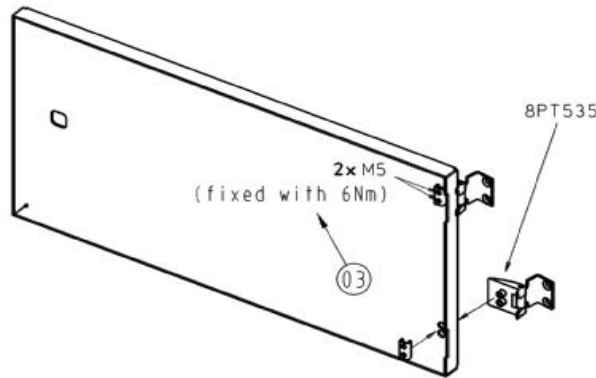
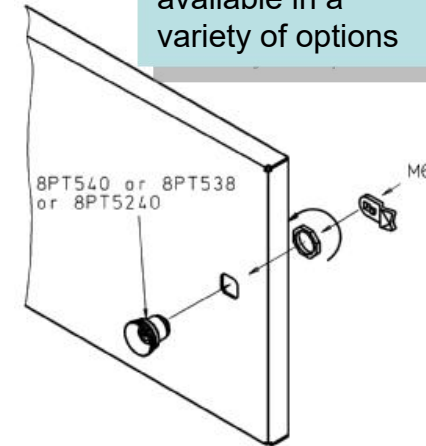

Ground wire

The maximum opening Angle of a single cabinet door is 180°

The opening Angle of the combined cabinet door is greater than 140°



SIVACON 8PT Introduction

SIVACON 8PT Product design (Skeleton and shell)



低压
控制与配电
动力配电中心

Low Voltage
Power Control
and Distribution
Power Distribution Center

2 structural forms

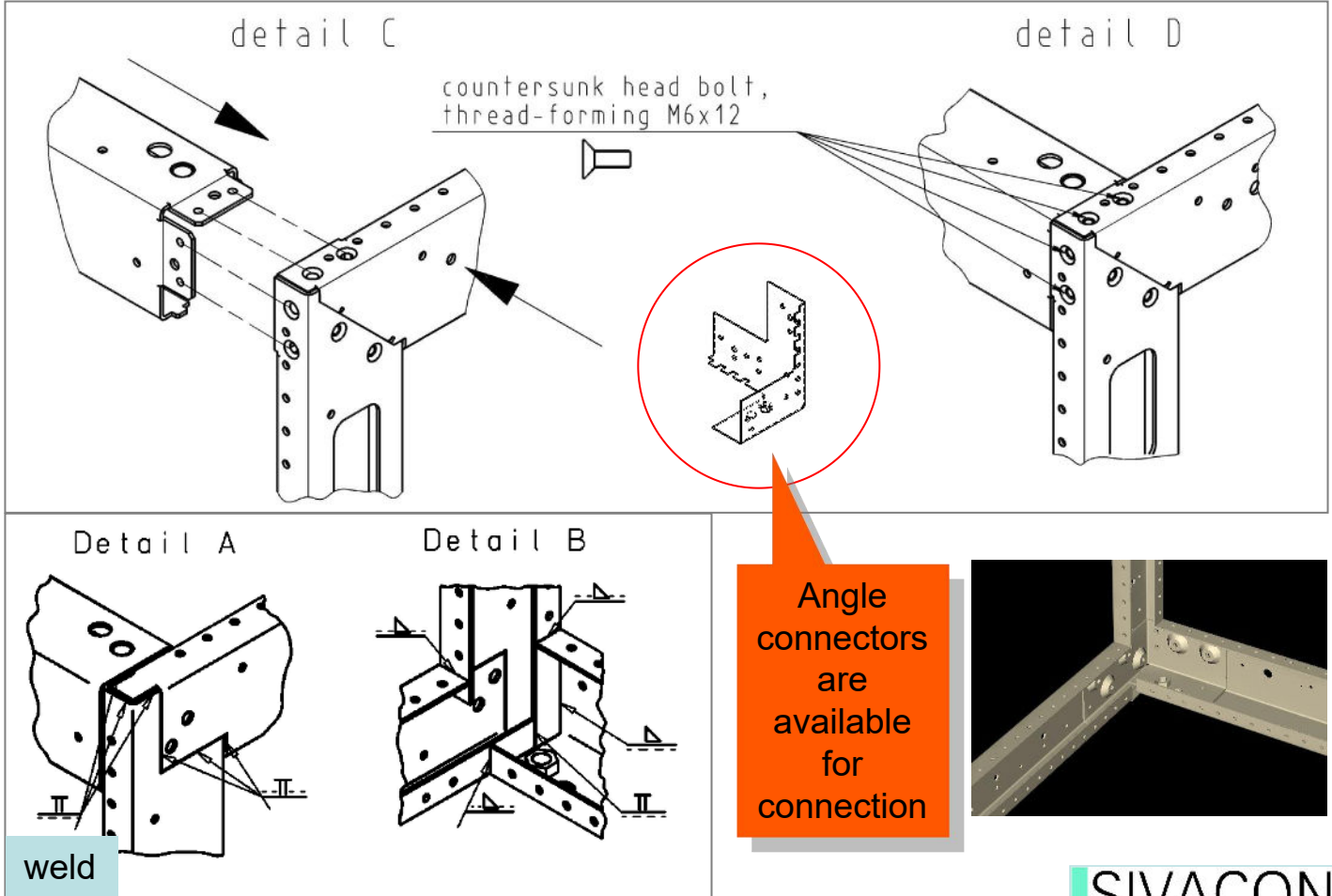

Product design



SIVACON 8PT Introduction

SIVACON 8PT Product design (Skeleton and shell)



低压
控制与配电
动力配电中心

Low Voltage
Power Control
and Distribution
Power Distribution Center

www.siemens.com/lowvoltage

Product design

Cabinet top

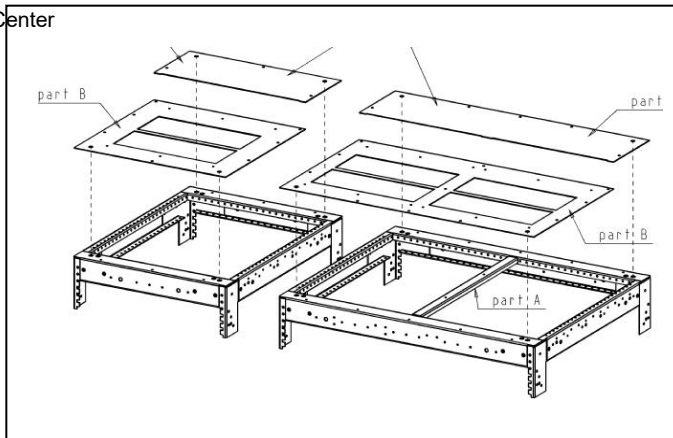

The top plate is bolted to the frame from above. The switch cabinet can be lifted without removing the top plate.

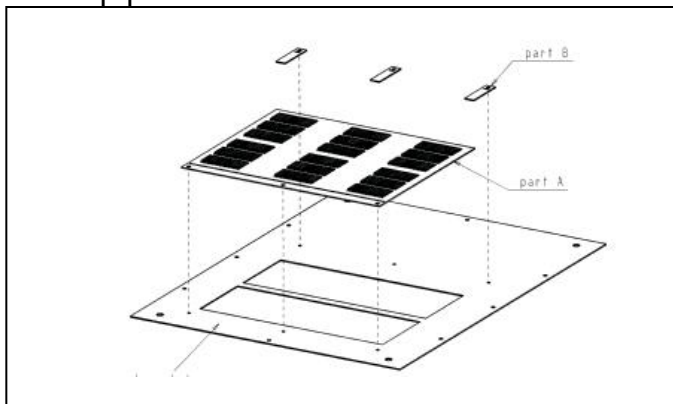

The roof is fitted with a pressure relief device

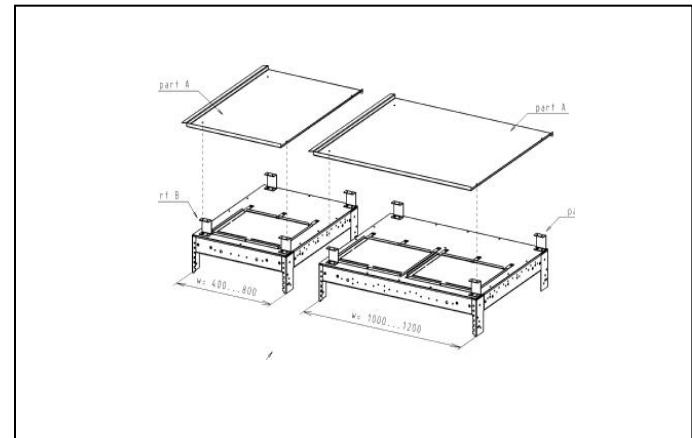

Roof panels with IPX1 or IPX2 protection grades will be delivered as accessories and installed 100mm above the top of the cabinet.



Lifting bracket



SIVACON 8PT Introduction

SIVACON 8PT Product design (Skeleton and shell)

Main feature

- ▶ The mounting holes on the skeleton are 25mm in modulus, and there are various combination schemes
- ▶ Various flexible cabinet doors can meet different requirements
- ▶ The maximum opening Angle of the door is 180°
- ▶ Spring lock can reliably prevent the door from popping open accidentally
- ▶ Cabinet top with pressure release device



低压
控制与配电
动力配电中心

Low Voltage
Power Control
and Distribution
Power Distribution Center

www.siemens.com/lowvoltage

Product design

SIVACON 8PT Introduction

SIVACON 8PT Product design (Skeleton and shell)

Size and material

height [mm]	width [mm] (Depends on the cabinet type)	depth [mm] (Depends on the form of the bus)
2200	600,800,1000	600,800
2600	1200,1600	1000,1200

Surface treatment	Optional electrostatic spraying, spray painting or galvanizing
Materials	The thickness of the steel plate is as follows (ordinary cold-rolled steel plate or aluminum-zinc plate): Skeleton: 2.5 mm Shell: 2.0 mm
According to IEC 60529	IP 30, IP 40, IP 42 Ventilated cabinet
Level of protection	IP 40, IP 54 Non-ventilated cabinet

SIVACON 8PT Introduction

SIVACON 8PT Product Design (Horizontal Bus System)



低压
控制与配电
动力配电中心

Low Voltage
Power Control
and Distribution
Power Distribution Center

Layout of horizontal bus bars

3/1

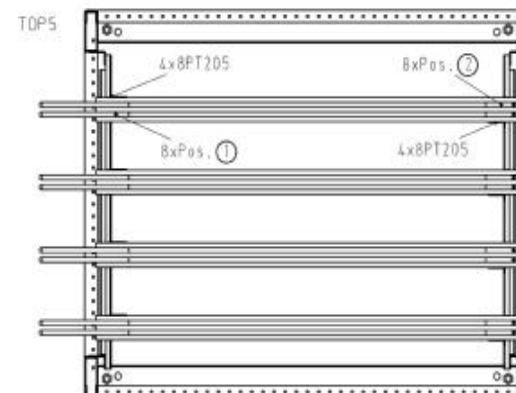
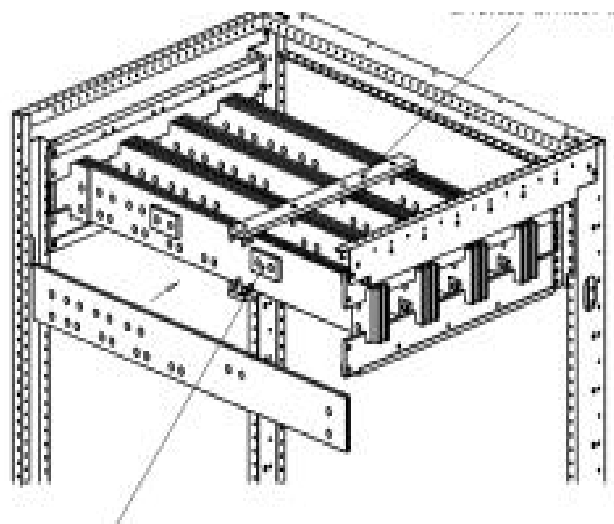

Product design

The horizontal main bus cable is located at the top of the cabinet and occupies a height space of 300mm

When the rated current is >4000A, 400 bus compartments are added to the top of the cabinet.



SIVACON 8PT Introduction

SIVACON 8PT Product Design (Horizontal Bus System)



低压
控制与配电
动力配电中心

Low Voltage
Power Control
and Distribution
Power Distribution Center

www.siemens.com/lowvoltage

Main structure

Product design

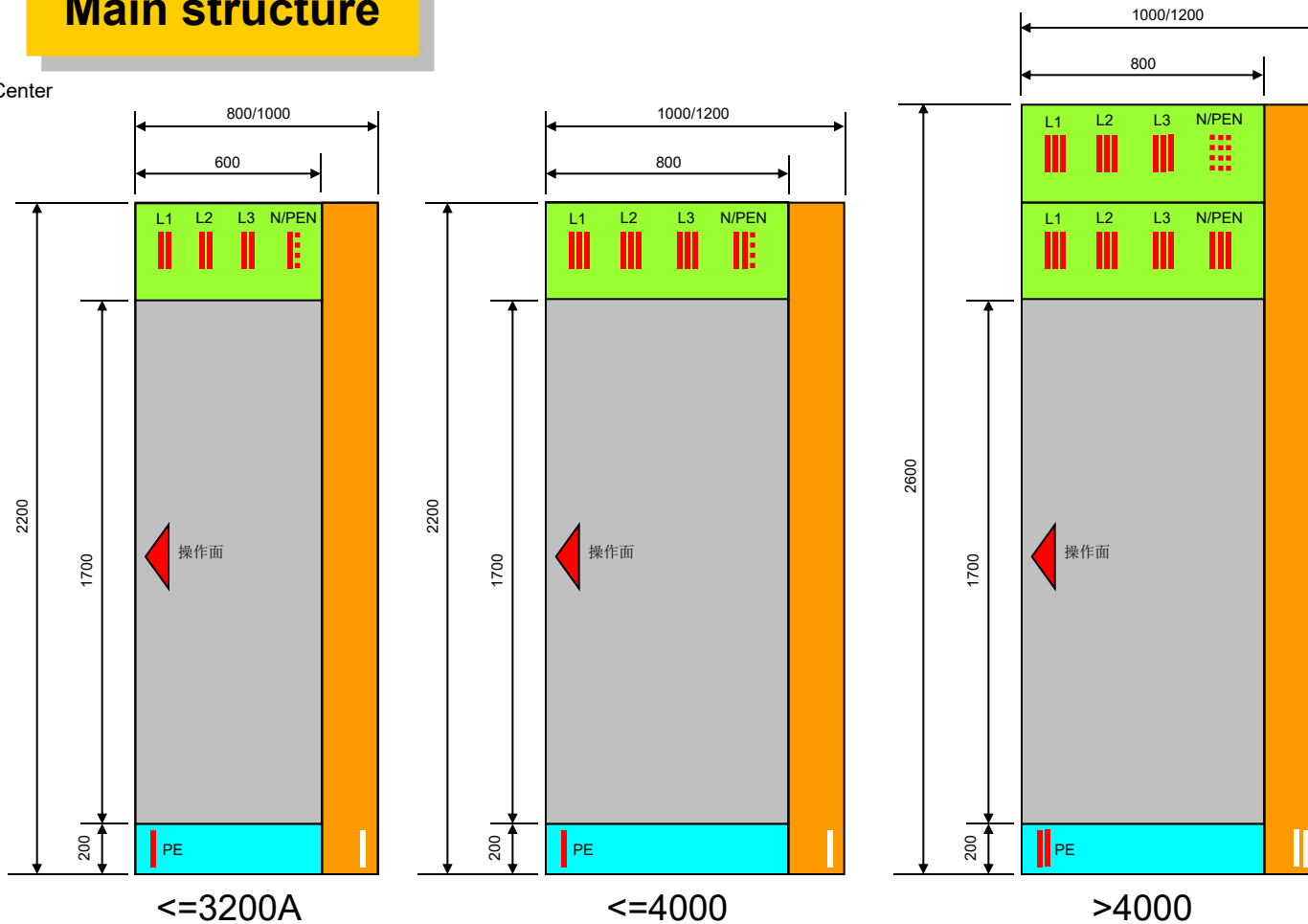

SIVACON 8PT Introduction

SIVACON 8PT Product Design (Horizontal Bus System)



低压控制与配电
 Low Voltage Power Control and Distribution
 动力配电中心
 Power Distribution Center

www.siemens.com/lowvoltage

Product design

Tank depth

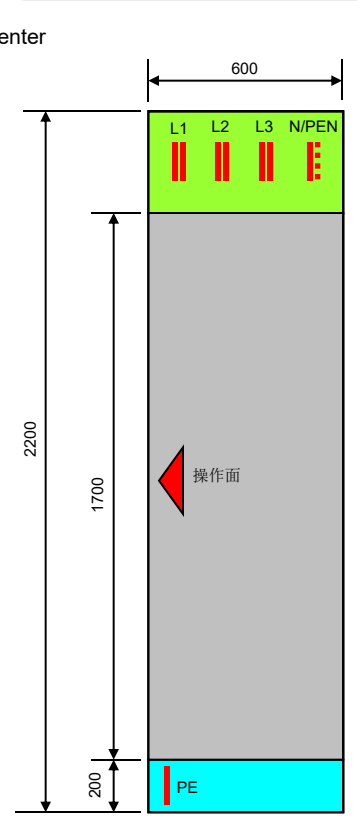

Front door cable bottom outlet

Cabinet depth is only related to the number of bus bars

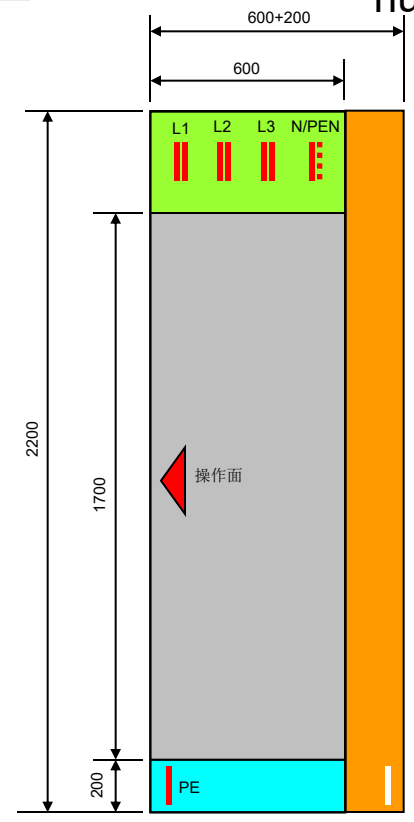

Front door top cable outlet

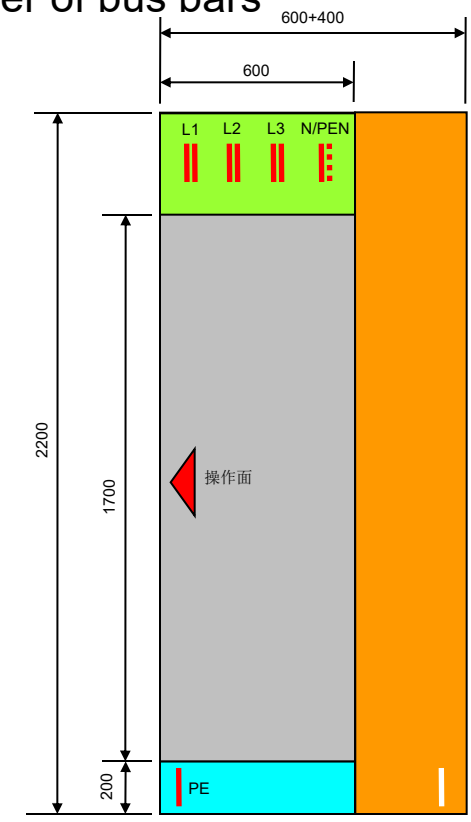

Rear door connection



SIVACON 8PT Introduction

SIVACON 8PT Product Design (Horizontal Bus System)



低压
控制与配电
动力配电中心

Low Voltage
Power Control
and Distribution
Power Distribution Center

www.siemens.com/lowvoltage

Product design

Cabinet depth (triple busbar)

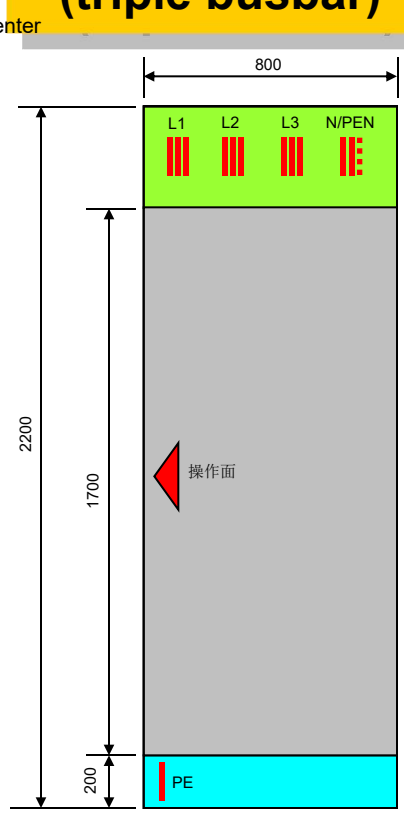

Front door
cable
bottom
outlet

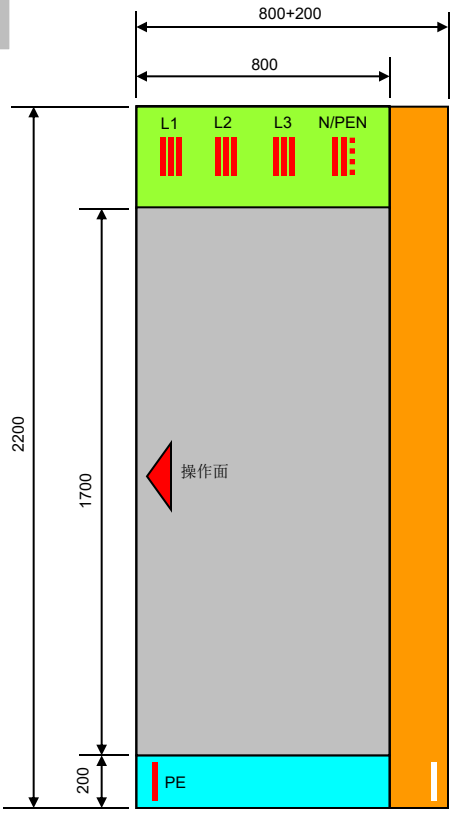

Front door
top cable
outlet

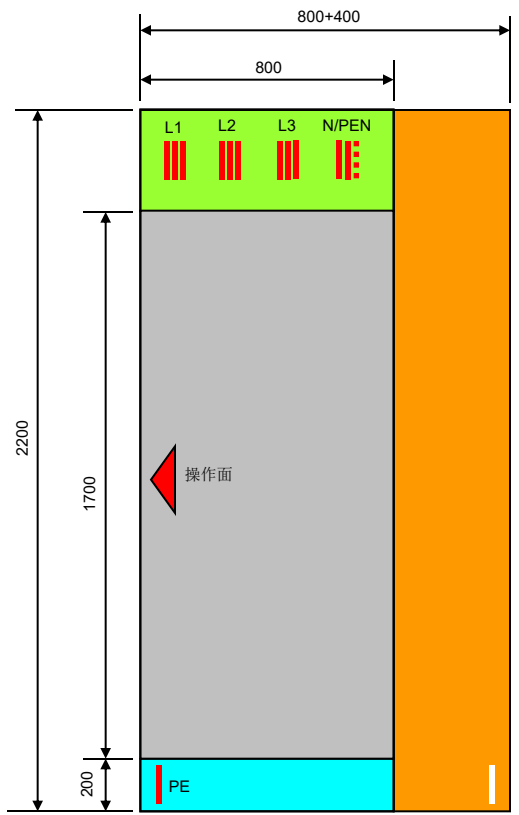

Rear door
connection



SIVACON 8PT Introduction

SIVACON 8PT Product Design (Horizontal Bus System)

Bus carrying capacity

to 3200 A

to 4000 A

to 7400 A

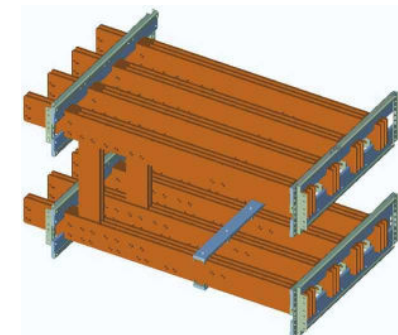
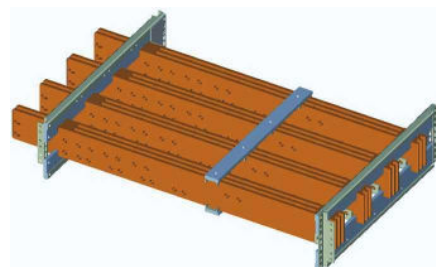
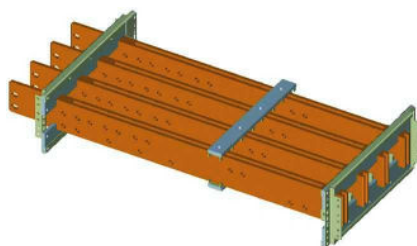

Phase conductor(L1, L2, L3) Quantity , size [mm]	Unventila ted type [A]	Ventilat ed type [A]	I_{pk} / I_{cw} [kA]	heigh t [mm]	depth [mm]
2 x 100 x 10 3 x 100 x 10	2400 2950	3200 4000	200/80 250/100	2200 2200	600, 800, 1000 800, 1000, 1200
3 x 100 x 10 + 3 x 100 x 10	5400	7400	375/150	2600	800, 1000, 1200

Rated current at ambient temperature of 35 ° C



低压
控制与配电
动力配电中心

Low Voltage
Power Control
and Distribution
Power Distribution Center

www.siemens.com/lowvoltage

Product design



SIVACON 8PT Introduction

SIVACON 8PT Product Design (Horizontal Bus System)



Busbar support

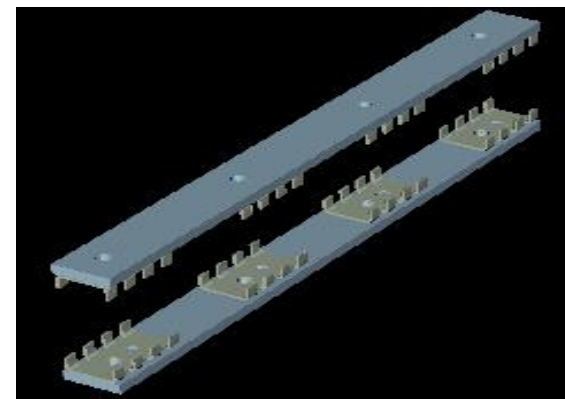
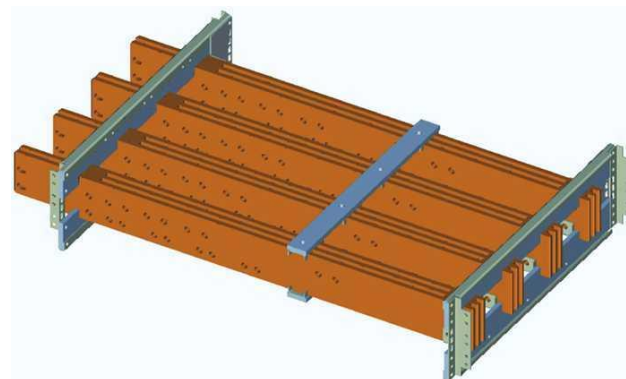
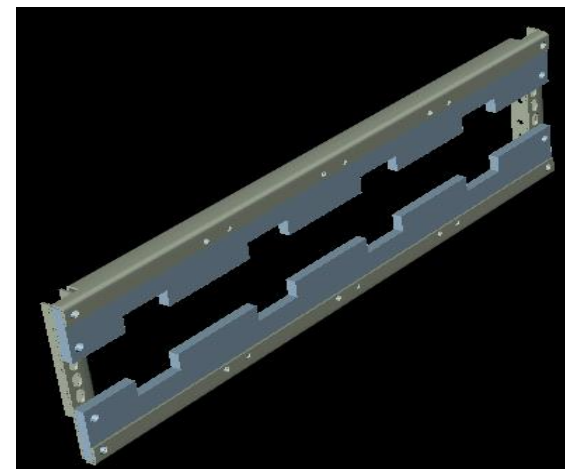
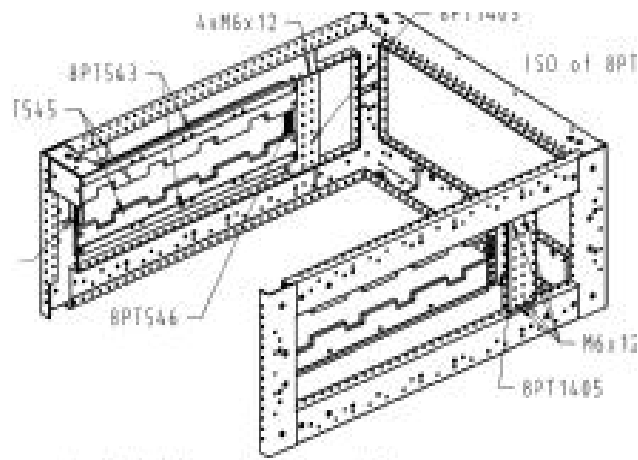

低压
控制与配电
动力配电中心

Low Voltage
Power Control
and Distribution
Power Distribution Center

www.siemens.com/lowvoltage

Product design



SIVACON 8PT Introduction

SIVACON 8PT Product Design (Horizontal Bus System)



低压
控制与配电
动力配电中心

Low Voltage
Power Control
and Distribution
Power Distribution Center

www.siemens.com/lowvoltage

The connection of the bus bar

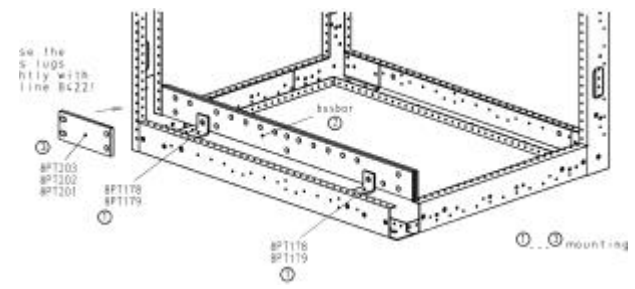
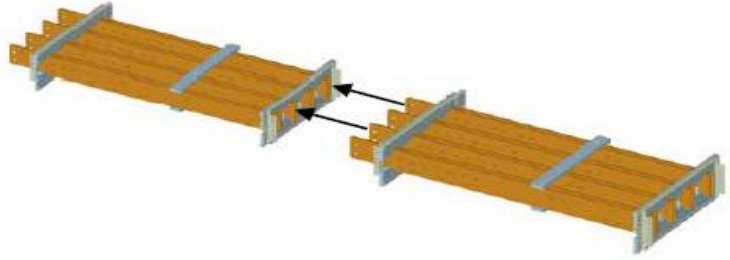

Product design

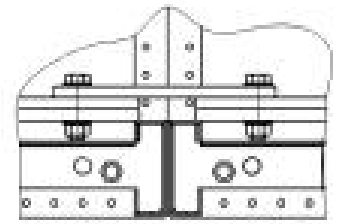
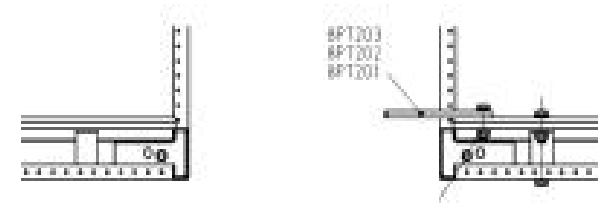
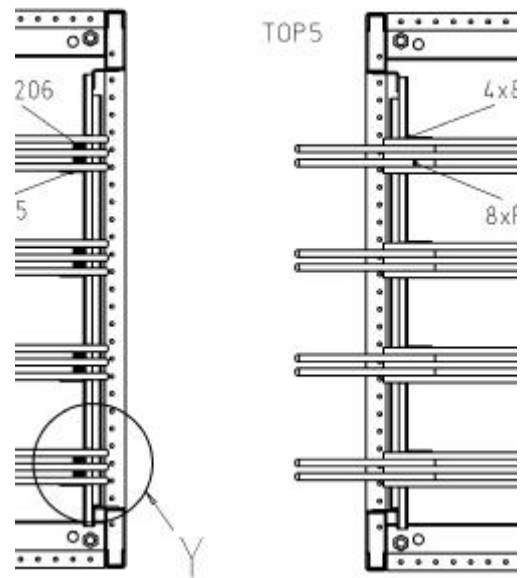

SIVACON 8PT Introduction

SIVACON 8PT Product Design (Horizontal Bus System)

SIVACON

低压
控制与配电
动力配电中心Low Voltage
Power Control
and Distribution
Power Distribution Centerwww.siemens.com/lowvoltage

Product design

Main feature

- ▶ The standardised design of the main busbar is located at the top of the cabinet
- ▶ The maximum rated current of the main bus is up to 7400 A
- ▶ Rated current rating according to customer requirements
- ▶ Rated peak withstand current (I_{pk}) up to 375kA
- ▶ The main bus compartment is isolated from the device compartment
- ▶ From the top, it is convenient to connect the bus bars between the transport units



SIVACON 8PT Introduction

SIVACON 8PT Product Design (Frame circuit breaker solution)



低压
控制与配电
动力配电中心
Low Voltage
Power Control
and Distribution
Power Distribution Center
www.siemens.com/lowvoltage

Structural form

Main structure of the FCB rear cable

- ← Transverse connecting compartments → (Optional)
- Horizontal bus area
- ← Auxiliary electrical compartments
- ← Main electrical compartment →
- ← Cable connection compartment

Main structure of the FCB front cable

- ← Cable connection compartment
- ← Auxiliary electrical compartments

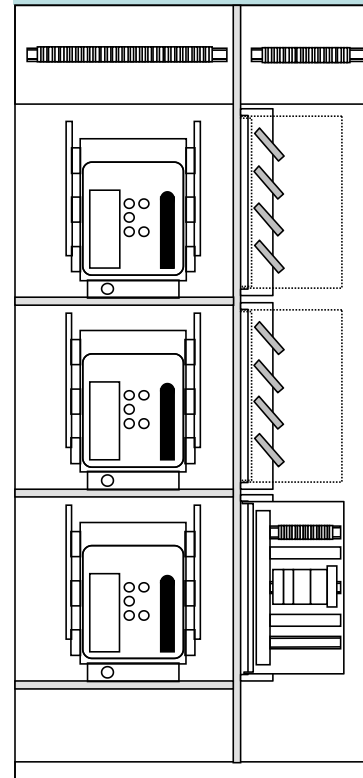

4/1

The frame circuit breaker cabinet can be used for incoming wire, outgoing wire and connection, and can be maintained by front door or rear door connection



SIVACON 8PT Introduction

SIVACON 8PT FCB1, BC cabinet size



低压
控制与配电
动力配电中心

Low Voltage
Power Control
and Distribution
Power Distribution Center

www.siemens.com/lowvoltage

FCB1, BC cabinet size

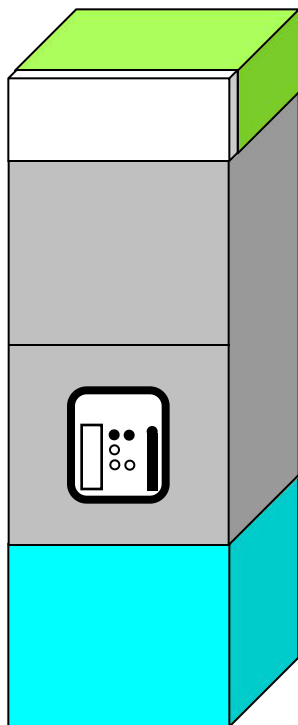

It can install all series of frame circuit breakers from 630A to 6300A, and some of the molded case circuit breakers above 630A

Minimum 600mm for single phase with two horizontal busbars; Minimum 800mm for single-phase three horizontal bus bars
Front connection depth

Minimum 1000mm for single phase with two horizontal busbars; Minimum 1200mm for single-phase 3 horizontal bus bars
Back connection depth

3200A and below:	3-pole	600mm	width
	4-pole	800mm	
4000A or higher:	3-pole	800mm	
	4-pole	1000mm	

Product design



SIVACON 8PT Introduction

SIVACON 8PT Product Design (Frame circuit breaker solution)



低压
控制与配电
动力配电中心

Low Voltage
Power Control
and Distribution
Power Distribution Center

www.siemens.com/lowvoltage

Product design

FCB2, FCB2BC cabinet dimensions

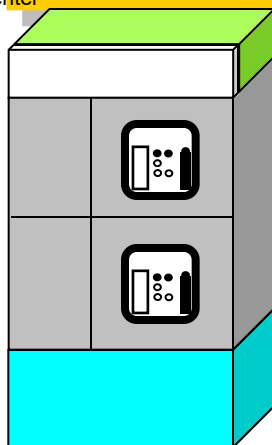

Only 2000A and 2500A frame Class II circuit breakers can be installed in the standard solution

The minimum front cable depth is 800mm and the width is 1000mm

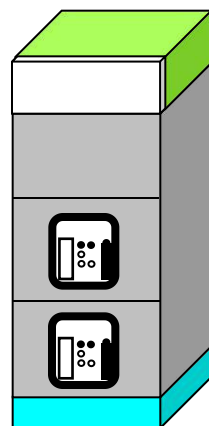

The minimum rear cable depth is 1200mm
Width 600mm for 3 poles, 800mm for 4 poles

A&D LV DM



SIVACON 8PT Introduction

SIVACON 8PT Product Design (Frame circuit breaker solution)



低压
控制与配电
动力配电中心

Low Voltage
Power Control
and Distribution
Power Distribution Center

www.siemens.com/lowvoltage

Product design

FCB3 cabinet exterior dimensions

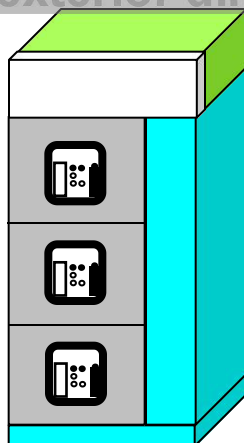

Only frame Class I circuit breakers below 1600A can be installed in the standard solution

The minimum front cable depth is 800mm
Width 1000mm or 1200mm

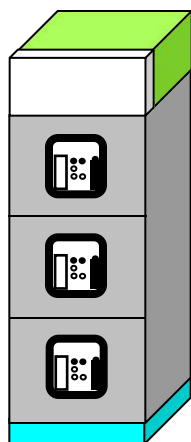

The minimum rear cable depth is 1200mm
Width 3 poles, 4 poles 600mm



SIVACON 8PT Introduction

SIVACON 8PT Product Design (Frame circuit breaker solution)



低压
控制与配电
动力配电中心

Low Voltage
Power Control
and Distribution
Power Distribution Center

Number and specifications of external cables



www.siemens.com/lowvoltage

Product design

3 1/2 Cable section mm ²	Number of connections (roots)			
	630A~1000A	1250A~1600A	2000A~2500A	3200A
≤240	4	6		
≤300			9	11



SIVACON 8PT Introduction

SIVACON 8PT Product Design (Frame circuit breaker solution)



低压
控制与配电
动力配电中心

Low Voltage
Power Control
and Distribution
Power Distribution Center

Main feature

Use 3WT or 3WL circuit breakers

Each cabinet can hold up to 3 circuit breakers

3 or 4 poles

Fixed or extracted

Test and separation position when closed

Short-circuit strength I_{pk} to 375kA
 I_{cw} to 150 kA, 1 s
to 100 kA, 3 s



Product design



SIVACON 8PT Introduction

SIVACON 8PT Product design (Fixed installation technology)



低压
控制与配电
动力配电中心

Low Voltage
Power Control
and Distribution
Power Distribution Center

Structure and dimensions of OFF1

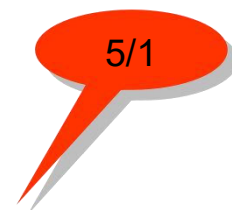

www.siemens.com/lowvoltage

Product design

Up to 160 A/ feed loop
(Fixed components only)

To 630 A/ feed loop
(Fixed or plug-in components)

A&D LV DM



SIVACON 8PT Introduction

SIVACON 8PT Product design (Fixed installation technology)



低压
控制与配电
动力配电中心

Low Voltage
Power Control
and Distribution
Power Distribution Center

www.siemens.com/lowvoltage

Product design

OFF1 component mounting

Element direct operation

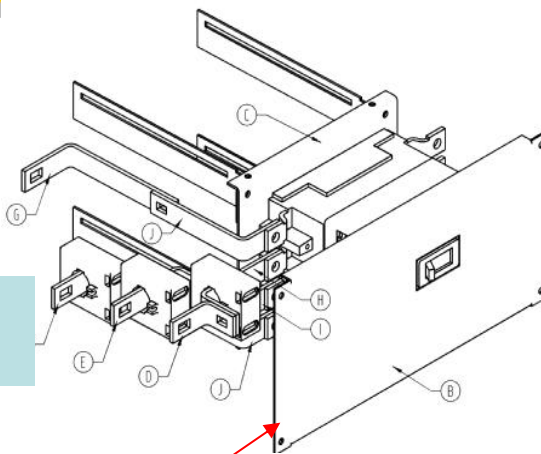

Door or cover



Adjustable mounting kit

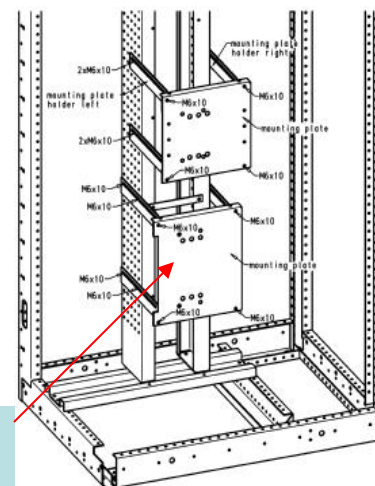

SIVACON 8PT Introduction

SIVACON 8PT Product design (Fixed installation technology)



低压
控制与配电
动力配电中心

Low Voltage
Power Control
and Distribution
Power Distribution Center

OFF1 Internal separation form

www.siemens.com/lowvoltage

Product design

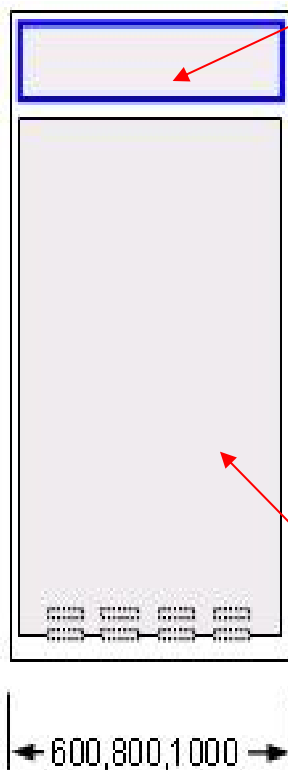

Horizontal bus
area

Component
mounting area

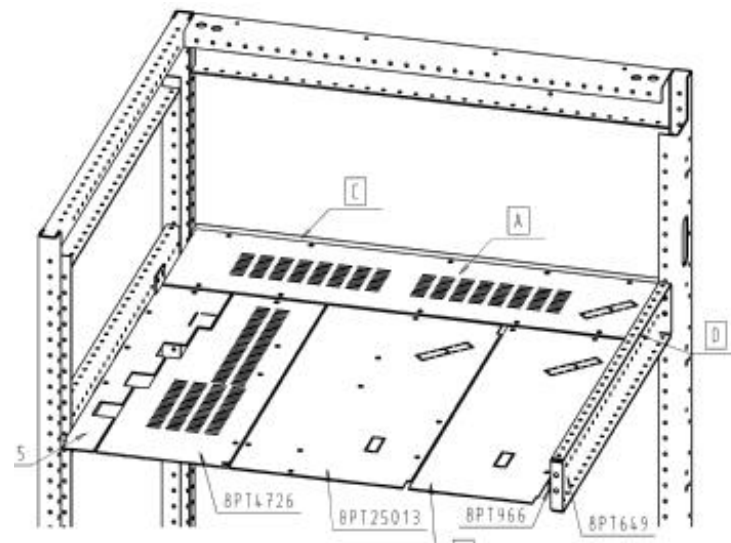

Separated form 2b



SIVACON 8PT Introduction

SIVACON 8PT Product design (Fixed installation technology)

OFF1 vertical bus systemx

Single size: 2X40X10 located on the left side of the cabinet



No punch connection form

Product design

section mm ²	Relationship between rated current and ambient temperature [A]						
	20°	25°	30°	35°	40°	45°	50°
Non-ventilated switchgear							
2x40x10	1290	1260	1230	1200	1170	1135	1100
Ventilated switchgear							
2x40x10	1505	1470	1435	1400	1365	1325	1285



SIVACON 8PT Introduction

SIVACON 8PT Product design (Fixed installation technology)



低压
控制与配电
动力配电中心

Low Voltage
Power Control
and Distribution
Power Distribution Center

www.siemens.com/lowvoltage

Product design

Structure and dimensions of OFF2

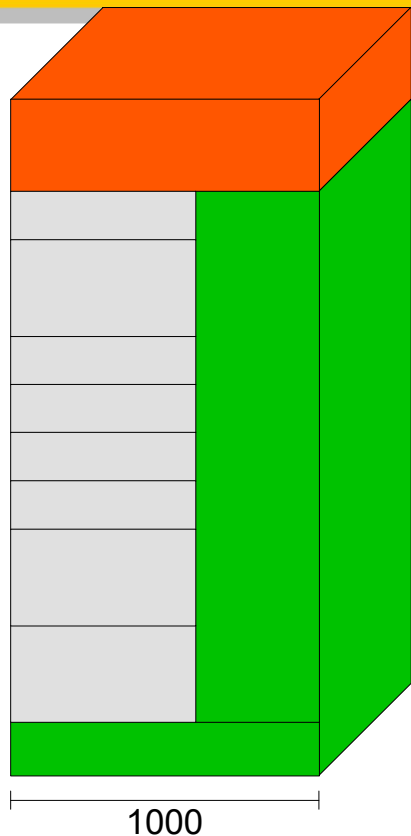

Loop less than or equal to 630A

Front door wiring only

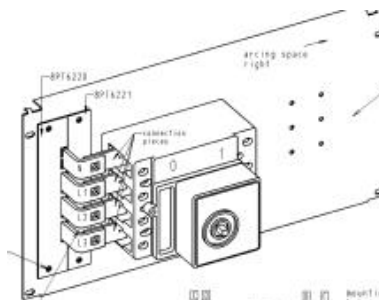

Rotary handle
outside the door
operation or open the
door directly
operation

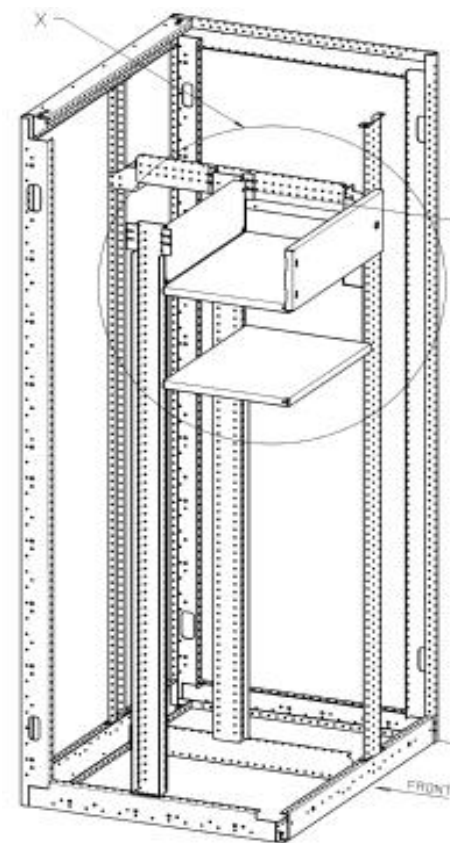

SIVACON 8PT Introduction

SIVACON 8PT Product design (Fixed installation technology)



低压
控制与配电
动力配电中心

Low Voltage
Power Control
and Distribution
Power Distribution Center

OFF2 vertical bus system

Maximum size: 2X40X10 Located at the rear of the cabinet

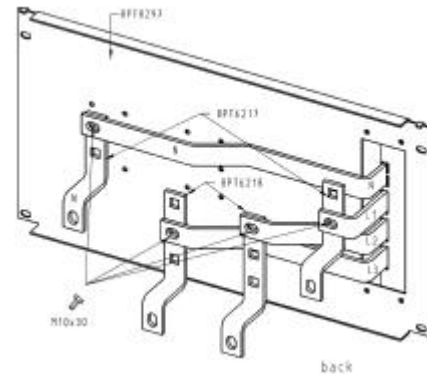
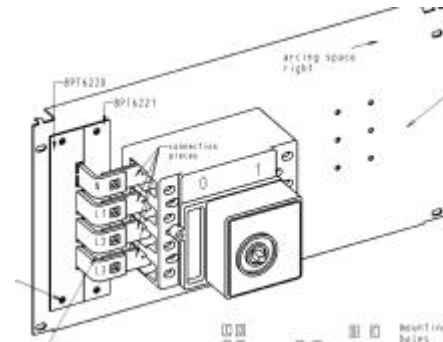
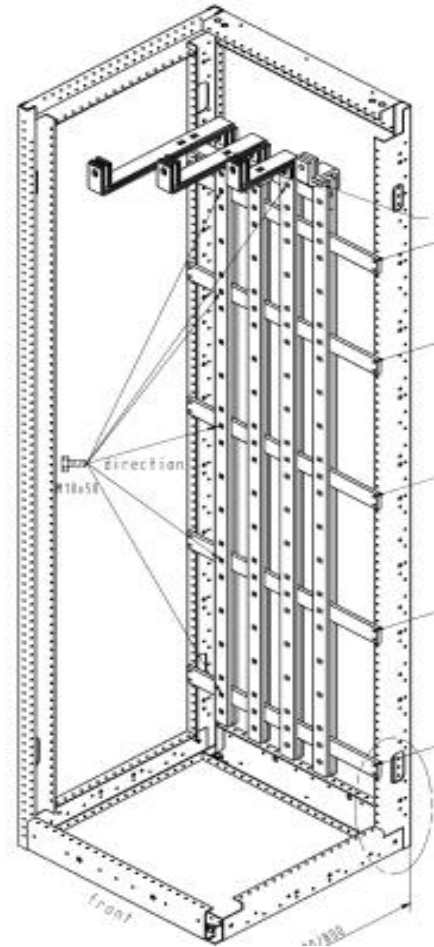

Product design

The connection mode is perforated



SIVACON 8PT Introduction

SIVACON 8PT Product design (Fixed installation technology)

OFF2 vertical bus system

Section [mm ²]	Relationship between rated current and ambient temperature [A]						
	20°	25°	30°	35°	40°	45°	50°
Non-ventilated switchgear							
1x40x10	860	840	820	800	780	755	735
1x60x10	1075	1050	1025	1000	975	945	920
2x40x10	1290	1260	1230	1200	1170	1135	1100
Ventilated switchgear							
1x40x10	915	895	870	850	825	805	780
1x60x10	1235	1210	1180	1150	1120	1090	1055
2x40x10	1505	1470	1435	1400	1365	1325	1285

Short-circuit strength (2x40x10)

$I_{pk} = 125 \text{ kA}$

$I_{cw} = 50 \text{ kA}, 1\text{s};$



低压
控制与配电
动力配电中心

Low Voltage
Power Control
and Distribution
Power Distribution Center

www.siemens.com/lowvoltage

Product design



SIVACON 8PT Introduction

SIVACON 8PT Product design (Fixed installation technology)



低压
控制与配电
动力配电中心

Low Voltage
Power Control
and Distribution
Power Distribution Center

www.siemens.com/lowvoltage

Product design

OFF2 Internal separation form

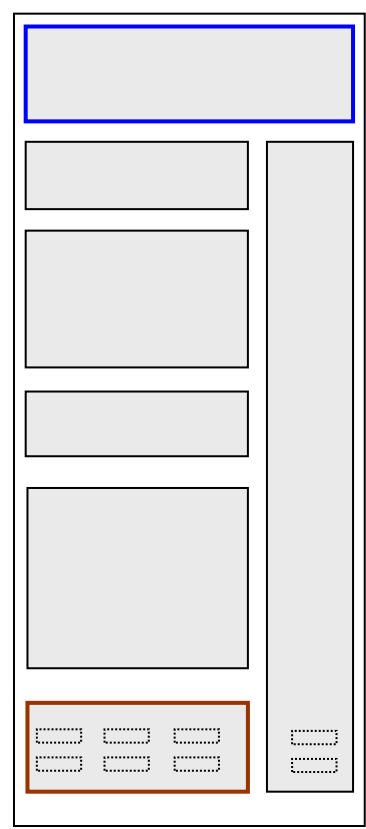

A&D LV DM

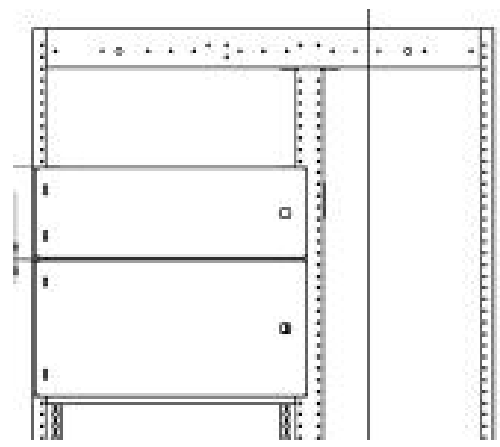

Separated form 4a



SIVACON 8PT Introduction

SIVACON 8PT Product design (Fixed installation technology)



低压
控制与配电
动力配电中心

Low Voltage
Power Control
and Distribution
Power Distribution Center

Structure and dimensions of OFF3

Only rear door open wiring form

www.siemens.com/lowvoltage

Product design



Rotary handle outside the door operation or open the door directly operation



SIVACON 8PT Introduction

SIVACON 8PT Product design (Fixed installation technology)



低压
控制与配电
动力配电中心

Low Voltage
Power Control
and Distribution
Power Distribution Center

www.siemens.com/lowvoltage

Product design

OFF3 vertical bus system

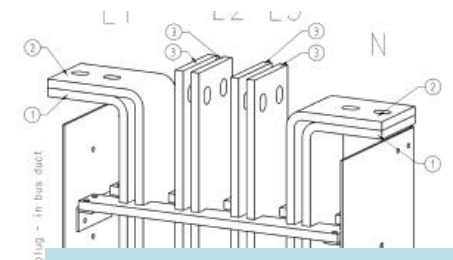
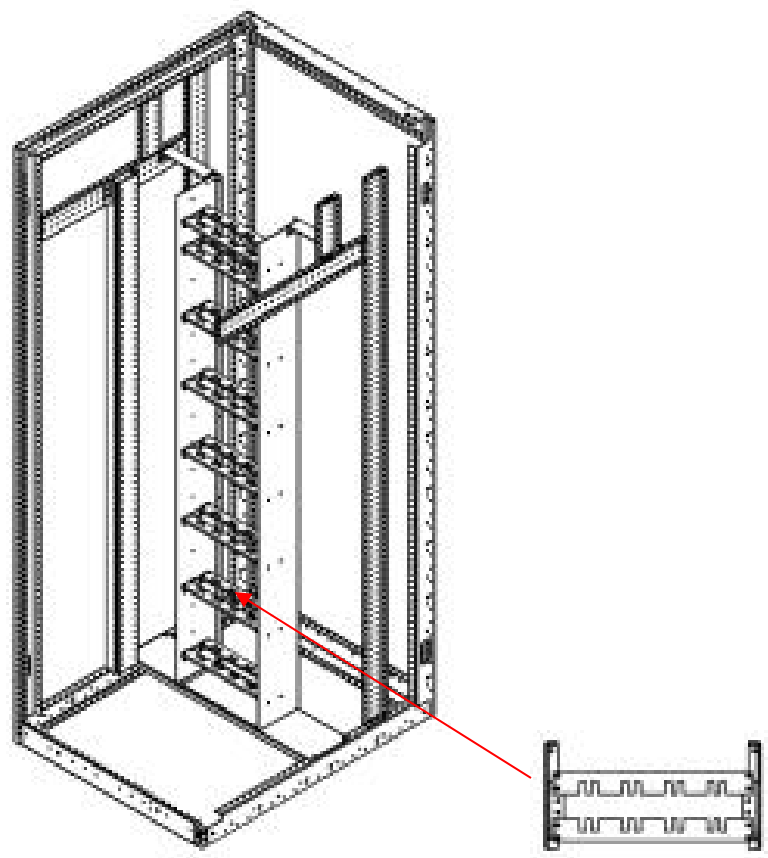

The connection mode without punching holes is adopted

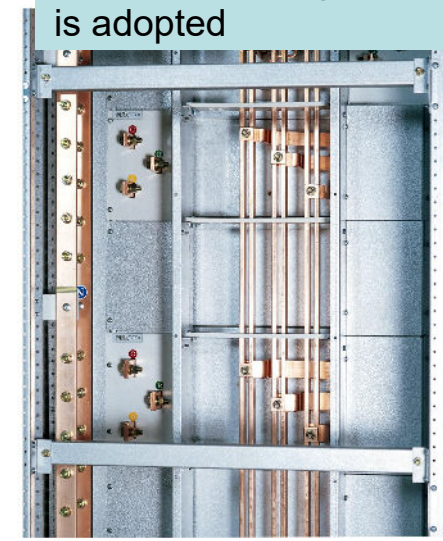

SIVACON 8PT Introduction

SIVACON 8PT Product design (Fixed installation technology)



低压
控制与配电
动力配电中心

Low Voltage
Power Control
and Distribution
Power Distribution Center

OFF3 vertical bus system

Section	Rated current at different ambient temperatures I_n [A]						
	20°	25°	30°	35°	40°	45°	50°
Non-fume hood							
2x40x10	1270	1230	1190	1150	1110	1060	1020
2x60x10	1600	1550	1500	1450	1400	1340	1290
2x80x10	1820	1760	1710	1650	1590	1530	1460
Fume hood body							
2x40x10	1470	1420	1380	1330	1280	1230	1180
2x60x10	1810	1750	1700	1640	1580	1520	1450
2x80x10	2090	2030	1970	1900	1830	1760	1680

Short-circuit strength(2x40x10)

$I_{pk} = 125$ kA
 $I_{cw} = 50$ kA, 1s;

Short-circuit strength(2x60x10, 2x80x10)

$I_{pk} = 163$ kA
 $I_{cw} = 65$ kA, 1s; 50 kA, 3 s



SIVACON 8PT Introduction

SIVACON 8PT Product design (Fixed installation technology)



低压
控制与配电
动力配电中心

Low Voltage
Power Control
and Distribution
Power Distribution Center

OFF3 Internal separation form

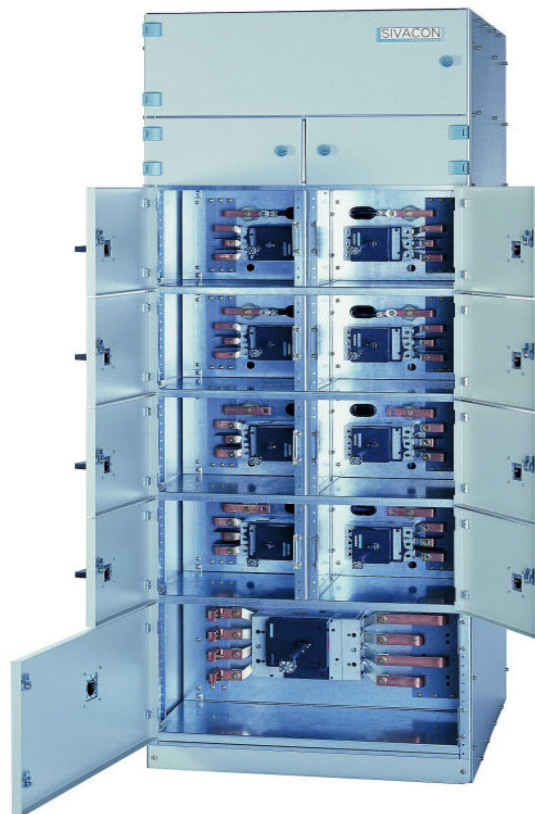

Product design

Separated form 3b, 4b



SIVACON 8PT Introduction

SIVACON 8PT Product design (Fixed installation technology)



低压
控制与配电
动力配电中心

Low Voltage
Power Control
and Distribution
Power Distribution Center

Size and structure of OFF4

www.siemens.com/lowvoltage

Product design

Add left and right cable rooms
Cabinet depth changes accordingly

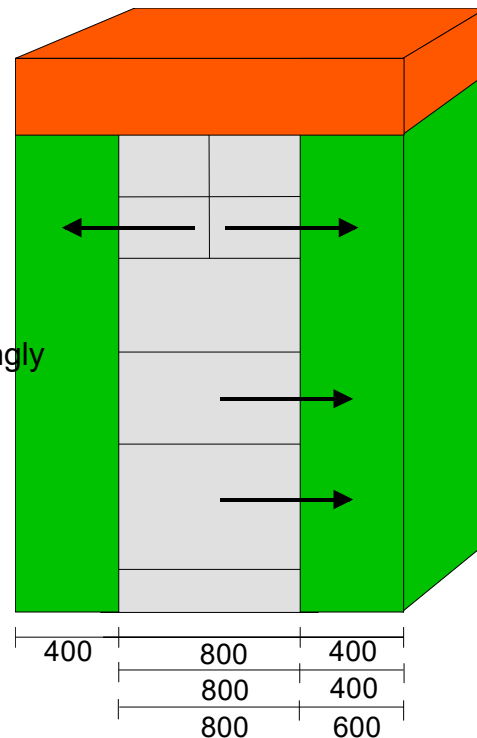

OFF3

OFF4



SIVACON 8PT Introduction

SIVACON 8PT Product design (Fixed installation technology)



低压
控制与配电
动力配电中心

Low Voltage
Power Control
and Distribution
Power Distribution Center

www.siemens.com/lowvoltage

Product design

OFFD1 structure and size

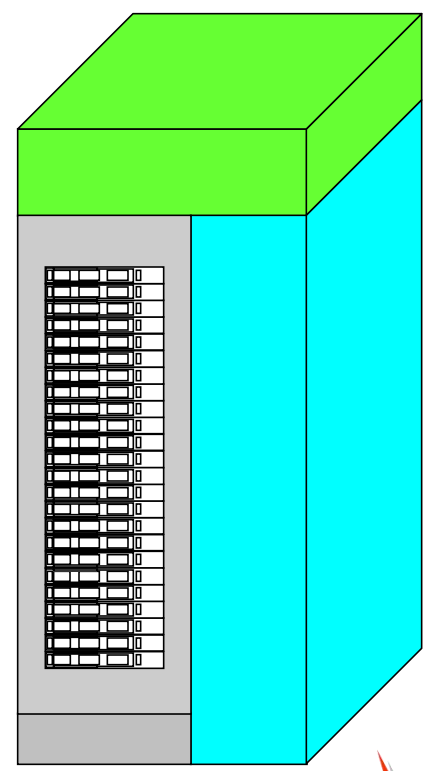

800
Up to 160 A/ loop

6/1

Front door wiring only



See 3NJ4 for information



SIVACON 8PT Introduction

SIVACON 8PT Product design (Fixed installation technology)



低压
控制与配电
动力配电中心

Low Voltage
Power Control
and Distribution
Power Distribution Center

OFFD1 Internal separation form

www.siemens.com/lowvoltage

Product design

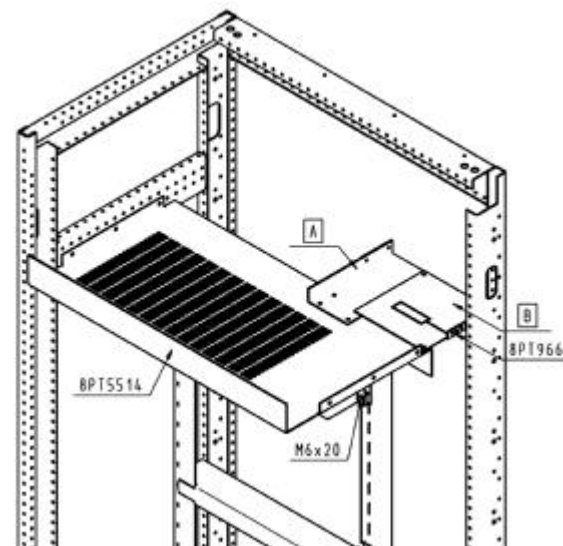

Max Do 2b



SIVACON 8PT Introduction

SIVACON 8PT Product design (Fixed installation technology)

OFFD1 vertical bus system

The vertical bus bar is located behind the cabinet

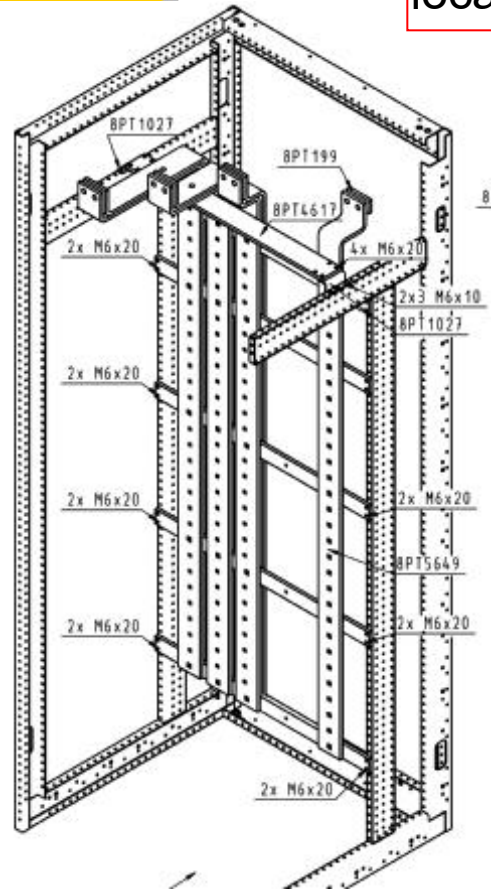

低压
控制与配电
动力配电中心

Low Voltage
Power Control
and Distribution
Power Distribution Center

www.siemens.com/lowvoltage

Product design



SIVACON 8PT Introduction

SIVACON 8PT Product design (Fixed installation technology)

OFFD1 Bus load

Section	Rated current at different ambient temperatures I_n [A]						
	20°	25°	30°	35°	40°	45°	50°
Unventilated type							
1x80x10	1470	1430	1390	1350	1310	1260	1220
2x80x10	1990	1940	1880	1830	1770	1710	1650
Ventilated type							
1x80x10	1620	1580	1530	1490	1440	1390	1340
2x80x10	2120	2060	2000	1940	1880	1820	1750

Short-circuit strength

$I_{pk} = 163 \text{ kA}$

$I_{cw} = 65 \text{ kA, 1 s; } 50 \text{ kA, 3 s}$

SIVACON 8PT Introduction

SIVACON 8PT Product design (Fixed installation technology)



低压
控制与配电
动力配电中心

Low Voltage
Power Control
and Distribution
Power Distribution Center

OFFD2 Structure and size

Front door wiring only

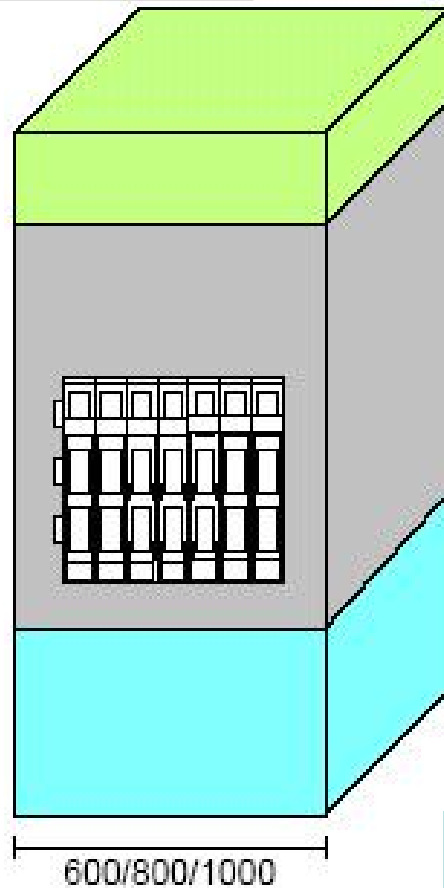

Loop less than or equal to 630A

Product design



SIVACON 8PT Introduction

SIVACON 8PT Product design (Fixed installation technology)



低压
控制与配电
动力配电中心

Low Voltage
Power Control
and Distribution
Power Distribution Center

www.siemens.com/lowvoltage

Product design

**Internal
partition**

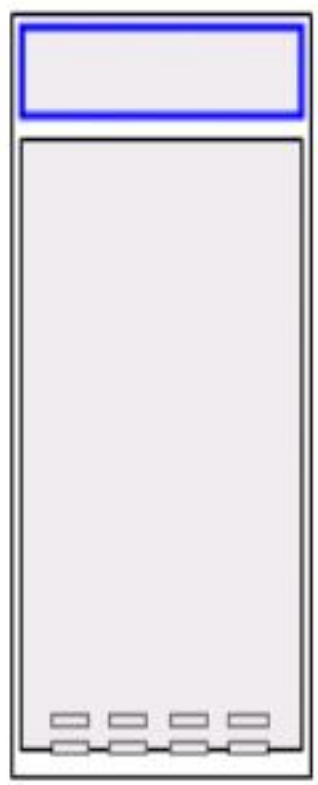

Up to 2b, maximum protection level IP42



SIVACON 8PT Introduction

SIVACON 8PT Product design (Fixed installation technology)

OFFD2 Bus load

Section	Rated current at different ambient temperatures I_n [A]						
	20°	25°	30°	35°	40°	45°	50°
	Unventilated type						
1x80x10 ¹⁾	1540	1510	1470	1430	1390	1350	1310
2x80x10 ¹⁾	2120	2070	2020	1970	1920	1860	1810
1x100x10 ²⁾	1920	1880	1830	1790	1740	1690	1640
2x100x10 ²⁾	2470	2420	2360	2300³⁾	2240	2180	2110
	Ventilated type						
1x80x10 ¹⁾	1880	1830	1790	1740	1700	1650	1600
2x80x10 ¹⁾	2600	2540	2480	2420	2350	2290	2220
1x100x10 ²⁾	2340	2290	2230	2180	2120	2060	2000
2x100x10 ²⁾	3010	2940	2870	2800³⁾	2730	2650	2570

- 1) 600 mm Cabinet width application
- 2) 800 / 1000 mm Cabinet width application

Short-circuit strength

$I_{pk} = 163 \text{ kA}$

$I_{cw} = 65 \text{ kA}, 1 \text{ s}; 50 \text{ kA}, 3 \text{ s}$



低压
控制与配电
动力配电中心

Low Voltage
Power Control
and Distribution
Power Distribution Center

www.siemens.com/lowvoltage

Product design



SIVACON 8PT Introduction

SIVACON 8PT Product design (plug-in technology)



低压
控制与配电
动力配电中心

Low Voltage
Power Control
and Distribution
Power Distribution Center

www.siemens.com/lowvoltage

OFPD structure and size

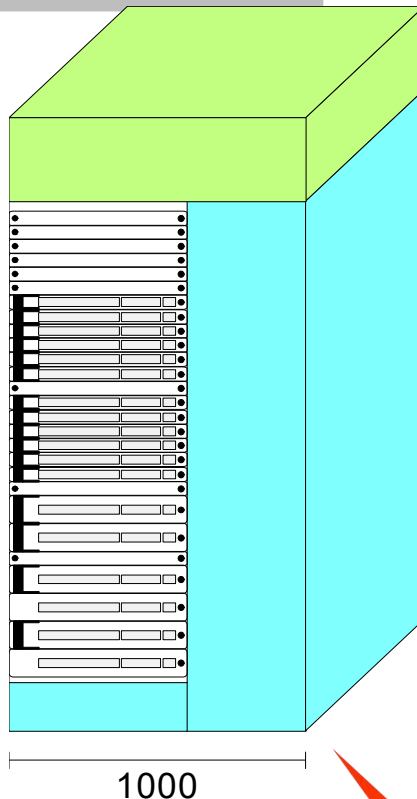

Product design

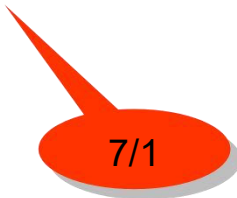

SIVACON 8PT Introduction

SIVACON 8PT Product design (plug-in technology)

Vertical bus of OFPD

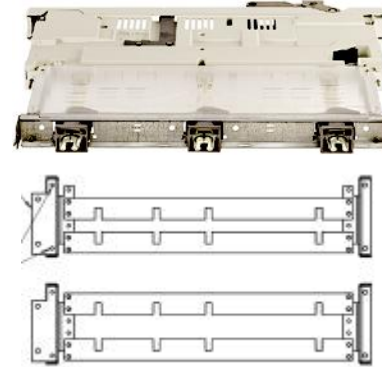
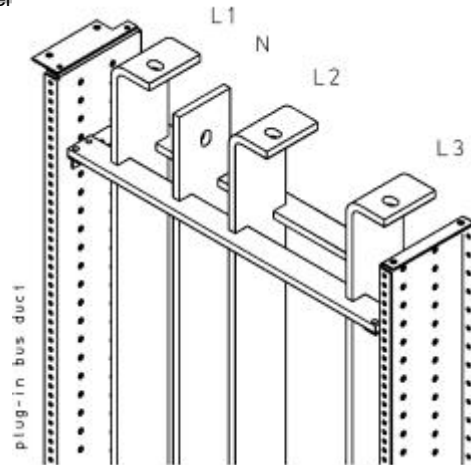

Section [mm ²]	The relationship between rated current and ambient temperature [A] Ventilated type						
	20°	25°	30°	35°	40°	45°	50°
80x10	2260	2210	2155	2100	2045	1985	1925

Short-circuit strength

$$I_{pk} = 110\text{kA} \quad I_{cw} = 50\text{ kA}, 1\text{ s}$$

SIVACON 8PT Introduction

SIVACON 8PT Product design (plug-in technology)



低压
控制与配电
动力配电中心

Low Voltage
Power Control
and Distribution
Power Distribution Center

www.siemens.com/lowvoltage

Product design

Main characteristics of OFPD

- ▶ Single loop rated current up to 630A
- ▶ Compact installation up to 34 loops
- ▶ Power off and replace fuse
- ▶ 400mm or 600mm cable connection compartments are available
- ▶ Protection level up to IP40
- ▶ Quick replacement is possible through the plug on the incoming side
- ▶ No need for full tank power outage to replace the circuit

See 3NJ6 for information

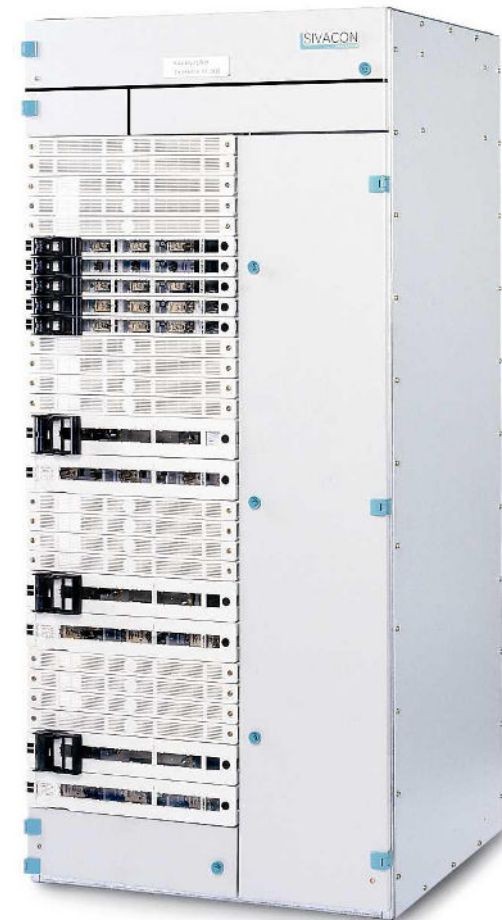

SIVACON
Siemens Technology

SIVACON 8PT 52

SIVACON 8PT Introduction

SIVACON 8PT Product design (plug-in technology)



低压
控制与配电
动力配电中心

Low Voltage
Power Control
and Distribution
Power Distribution Center

www.siemens.com/lowvoltage

**OFPM structure
and size**

The effective installation height is 1700mm;
Only the front door wiring form

8/1

Product design

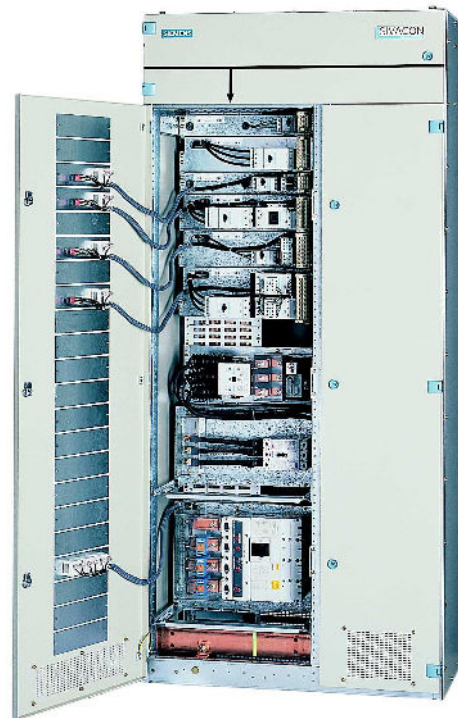

The feed circuit can reach 630A, and the motor
circuit can reach 250kW

SIVACON
Siemens Technology



SIVACON 8PT Introduction

SIVACON 8PT Product design (plug-in technology)



低压
控制与配电
动力配电中心

Low Voltage
Power Control
and Distribution
Power Distribution Center

Separation form and protection level

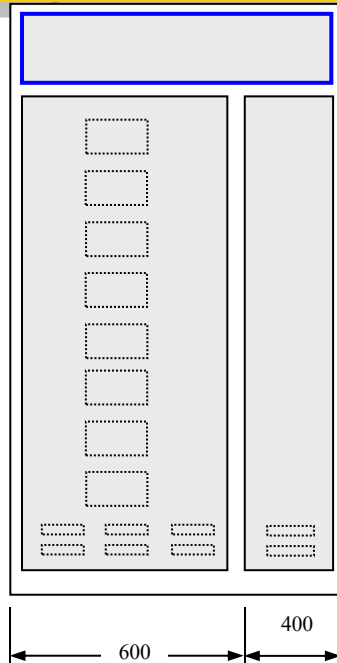

Form 2b
Unventilated
type ≤ IP 54
Ventilated type ≤ IP 42

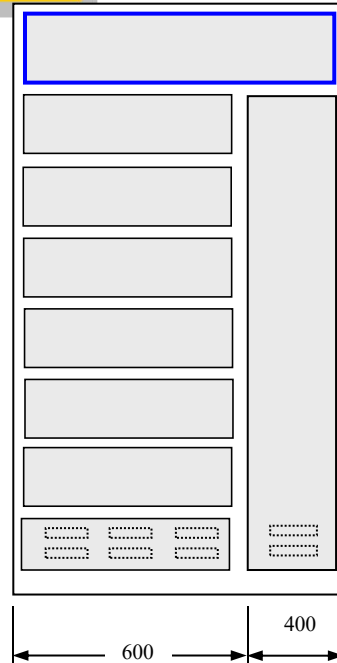

Form 4a
Unventilated
type ≤ IP 54
Ventilated type ≤ IP 42

IP20 shield



SIVACON 8PT Introduction

SIVACON 8PT Product design (plug-in technology)



低压
控制与配电
动力配电中心

Low Voltage
Power Control
and Distribution
Power Distribution Center

www.siemens.com/lowvoltage

Cabinet doors and dashboards

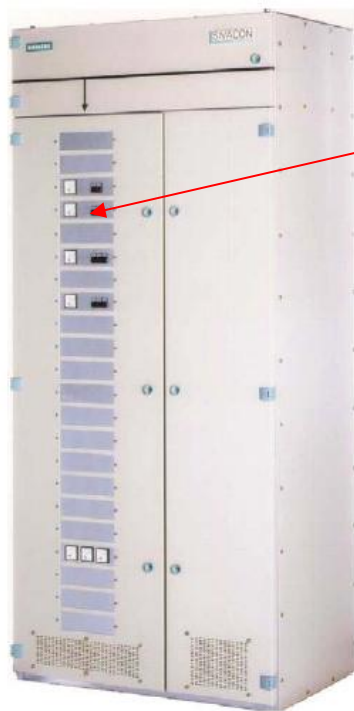

2b divider form cabinet door

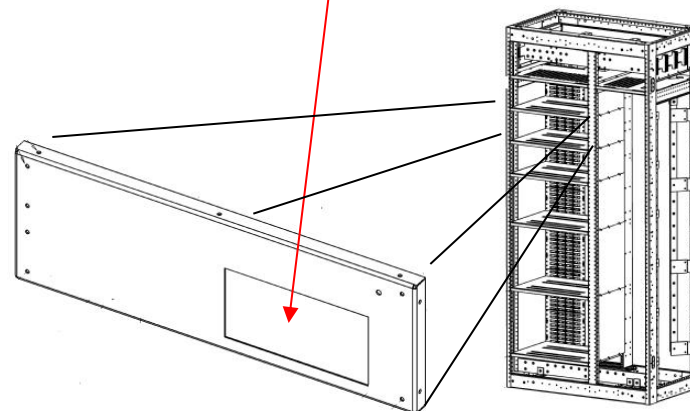
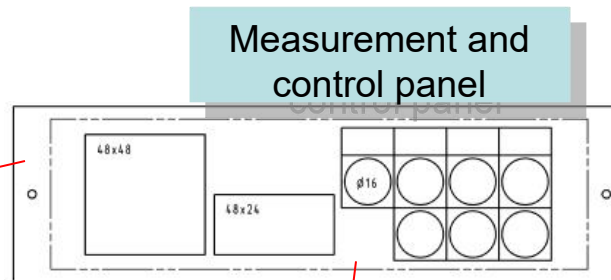

4a cabinet door in divided form



SIVACON 8PT Introduction

SIVACON 8PT Product design (plug-in technology)



低压
控制与配电
动力配电中心

Low Voltage
Power Control
and Distribution
Power Distribution Center

www.siemens.com/lowvoltage

OFPM module structure

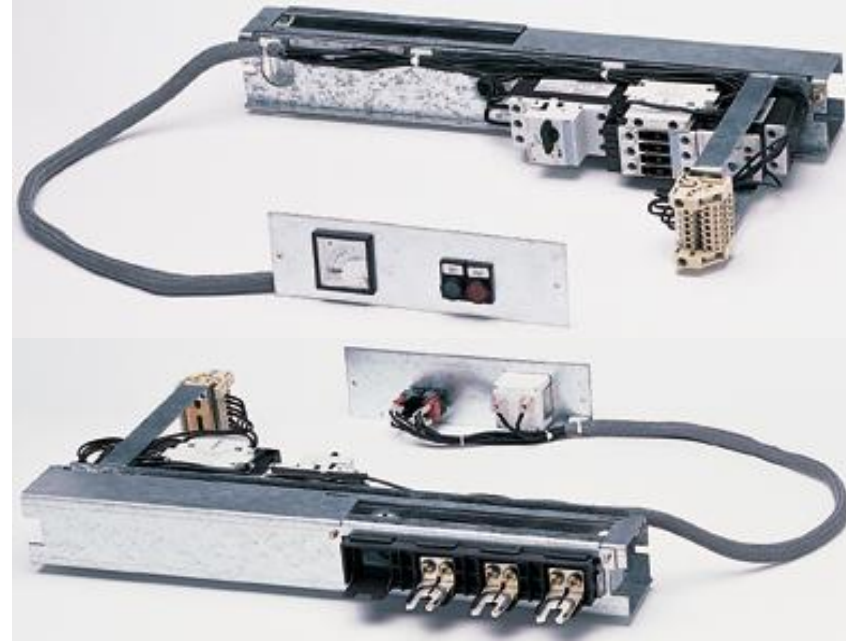

Primary contact cover cover

Primary component mounting plate

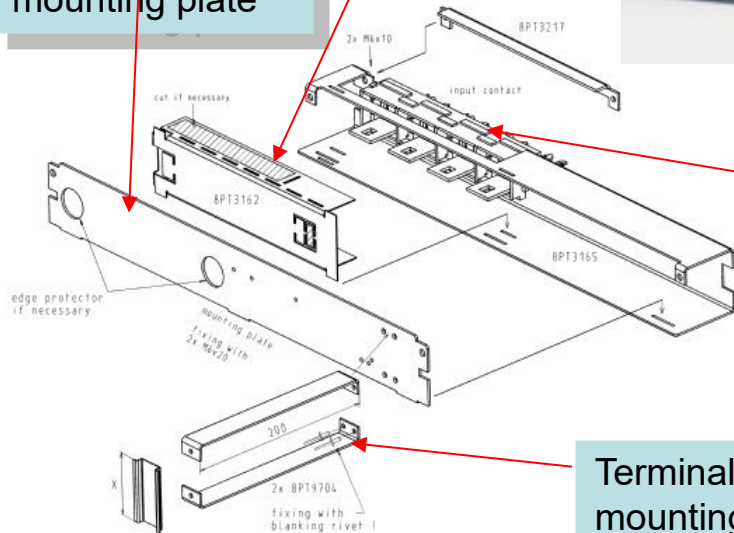

Only one set of incoming contacts

Terminal mounting plate



SIVACON 8PT Introduction

SIVACON 8PT Product design (plug-in technology)



低压
控制与配电
动力配电中心

Low Voltage
Power Control
and Distribution
Power Distribution Center

Vertical bus carrying capacity

Section	Rated current at different ambient temperatures I _n [A]						
	20°	25°	30°	35°	40°	45°	50°
Non-fume hood							
40x10	755	735	720	700	680	660	640
60x10	1075	1050	1025	1000	975	945	920
Fume hood body							
40x10	880	860	840	820	800	775	750
60x10	1260	1230	1200	1170	1140	1105	1075

Short-circuit strength

40X10: I_{pk} = 125kA, I_{cw} = 50 kA, 1s

60X10: I_{pk} = 163 kA I_{cw} = 65 kA, 1s; 50 kA, 3s



SIVACON 8PT Introduction

SIVACON 8PT Product design (plug-in technology)



低压
控制与配电
动力配电中心

Low Voltage
Power Control
and Distribution
Power Distribution Center

www.siemens.com/lowvoltage

Operation and maintenance



After removing the cable and fastening screws, you can directly insert or remove the module



SIVACON 8PT Introduction

SIVACON 8PT Product design (extraction technology)



低压
控制与配电
动力配电中心

Low Voltage
Power Control
and Distribution
Power Distribution Center

www.siemens.com/lowvoltage

OFW structure and size



Front door
connection

A&D LV DM

The effective installation
height is 1700mm

8/1

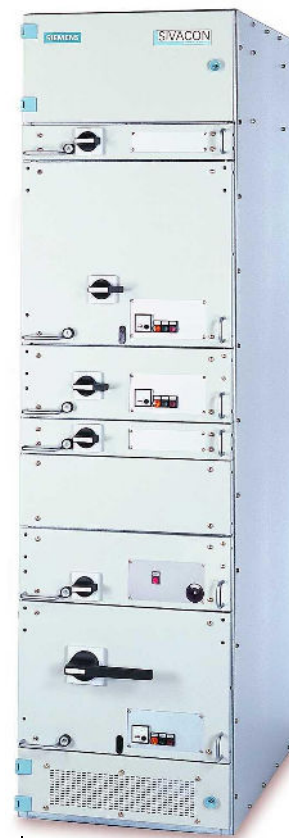

Rear door
connection



SIVACON 8PT 59



SIVACON 8PT Introduction

SIVACON 8PT Product design (extraction technology)



低压
控制与配电
动力配电中心

Low Voltage
Power Control
and Distribution
Power Distribution Center

Separation form and protection level

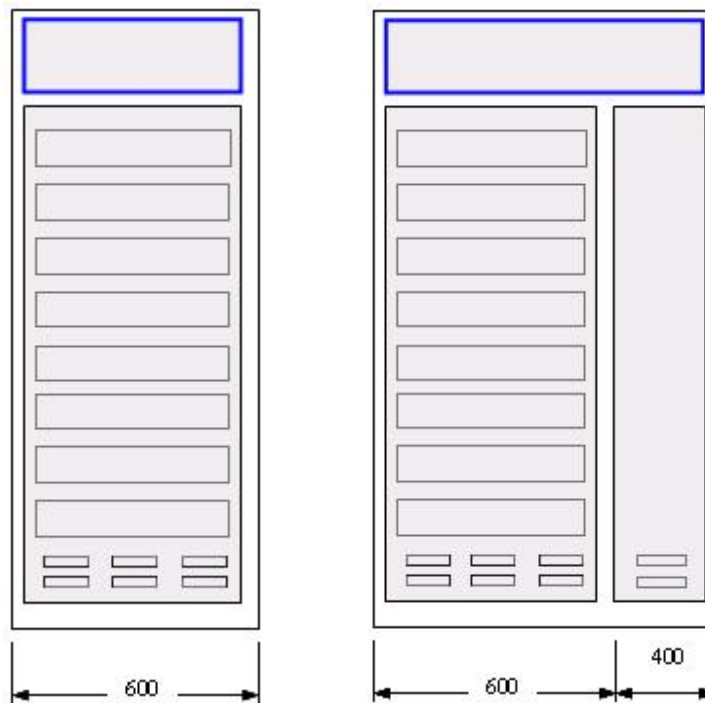

Form 3b, 4b
Non-ventilated \leq IP 54
Ventilated \leq IP 42

IP20 shield



The drawer is protected IP20 after withdrawal



SIVACON 8PT Introduction

SIVACON 8PT Product design (extraction technology)



低压
控制与配电
动力配电中心

Low Voltage
Power Control
and Distribution
Power Distribution Center

www.siemens.com/lowvoltage

Drawer frame construction

Mechanical interlocking mechanism

Realize the interlocking of circuit breaker and drawer operation, and limit the plug and pull of drawer in the test position

door: Handle hole open

Measurement and control panel

Position fixing mechanism

Drawer can be put in test and run position

Auxiliary contact propulsion mechanism

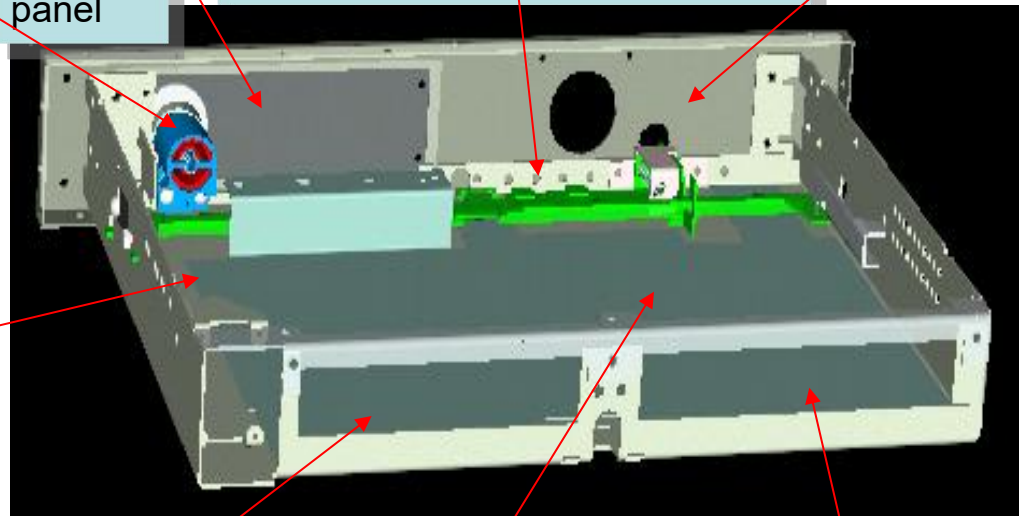

Exit the installation position of the primary contact

Bottom insulation partition

installation position of incoming primary contact

A&D



SIVACON 8PT Introduction

SIVACON 8PT Product design (extraction technology)



低压
控制与配电
动力配电中心

Low Voltage
Power Control
and Distribution
Power Distribution Center

www.siemens.com/lowvoltage

Drawer space

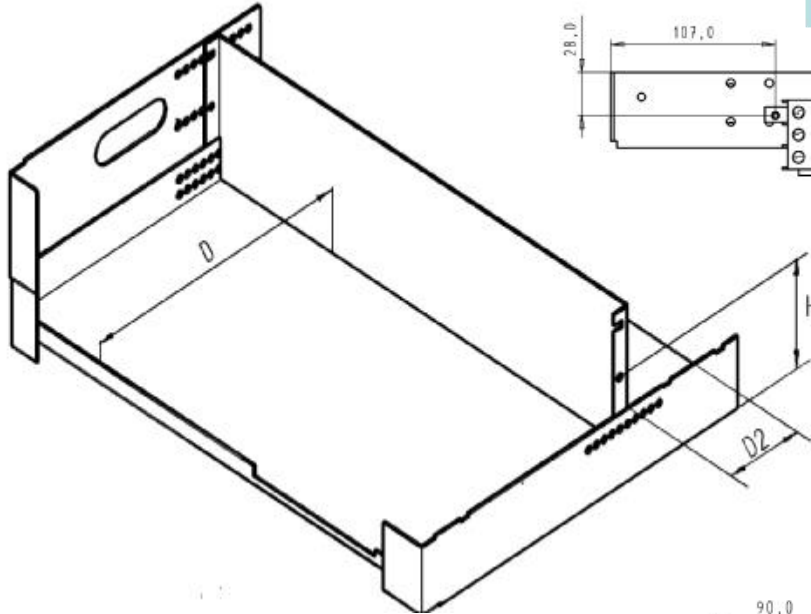

Front-end primary component
mounting depth: 202.5mm
Back-end secondary component
installation depth: 115mm

Feed circuit installation diagram

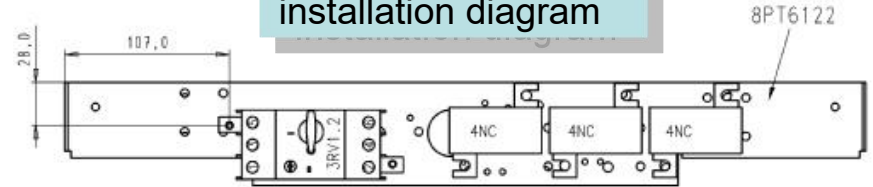

Motor circuit installation diagram

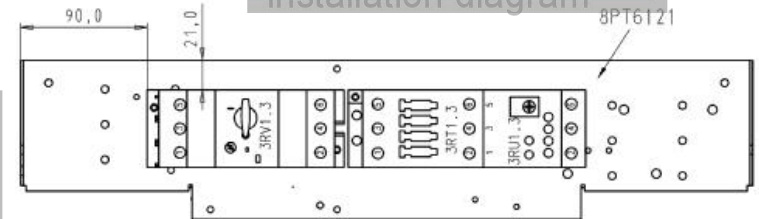

SIVACON 8PT Introduction

SIVACON 8PT Product design (extraction technology)



低压
控制与配电
动力配电中心

Low Voltage
Power Control
and Distribution
Power Distribution Center

www.siemens.com/lowvoltage

Secondary contact system

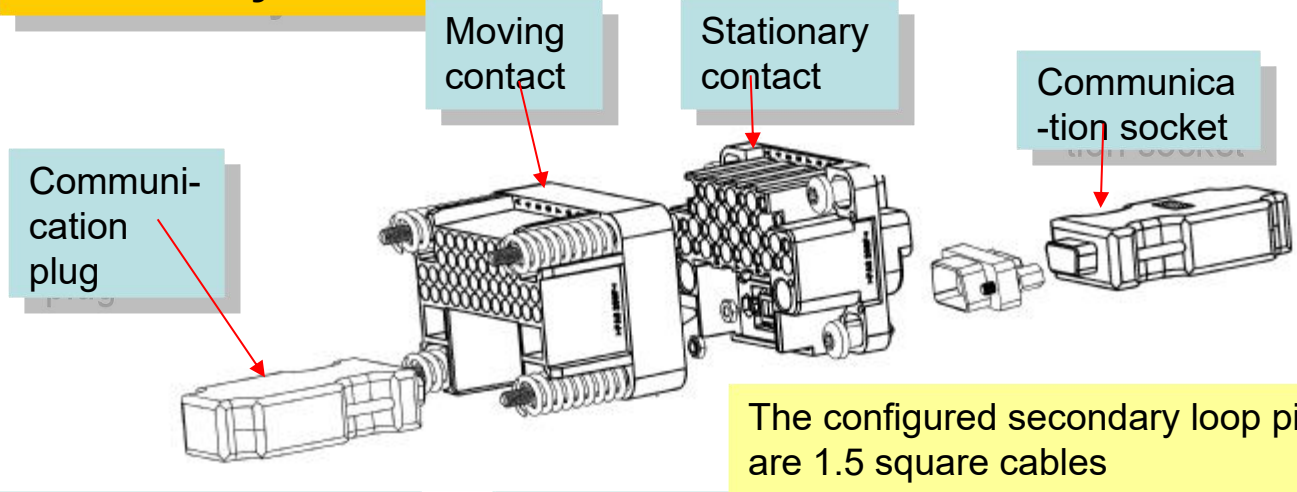

40 pins, operating voltage is 250V
(max. 40 contacts)

30 pins, operating voltage is 500V
(max. 30 contacts)

20 pins, operating voltage is 690V

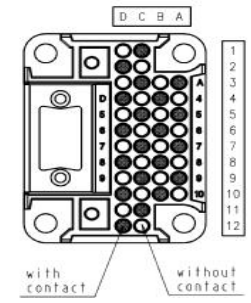
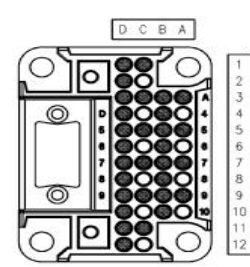
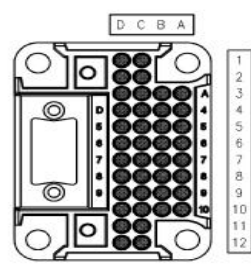

SIVACON 8PT Introduction

SIVACON 8PT Product design (extraction technology)



低压
控制与配电
动力配电中心

Low Voltage
Power Control
and Distribution
Power Distribution Center

www.siemens.com/lowvoltage

Drawer three position

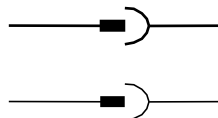
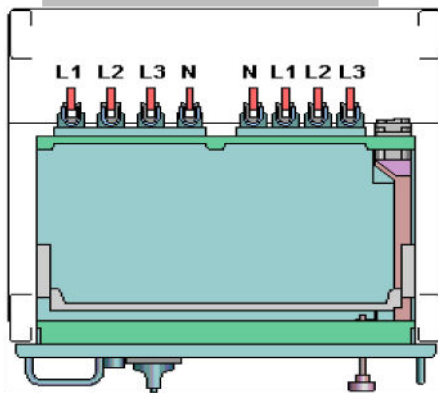

Connection position

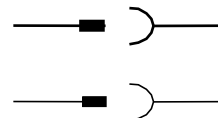
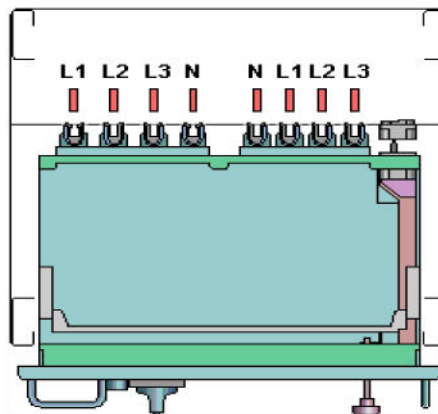

Separation position

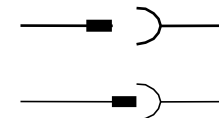
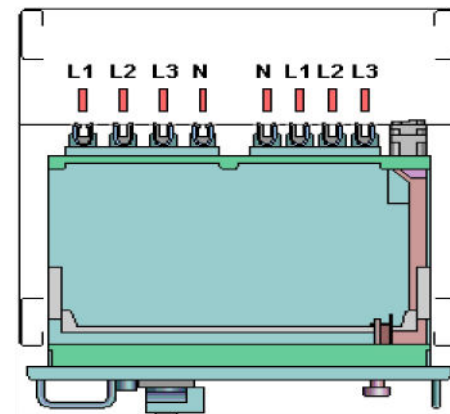

Test position

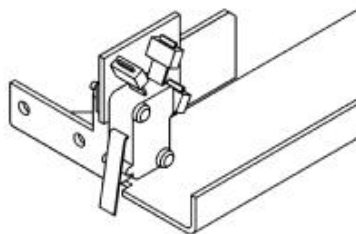

If necessary, a position signal switch can be installed on the secondary contact propulsion mechanism

SIVACON 8PT Introduction

SIVACON 8PT Product design (extraction technology)



低压
控制与配电
动力配电中心

Low Voltage
Power Control
and Distribution
Power Distribution Center

www.siemens.com/lowvoltage

Drawer front

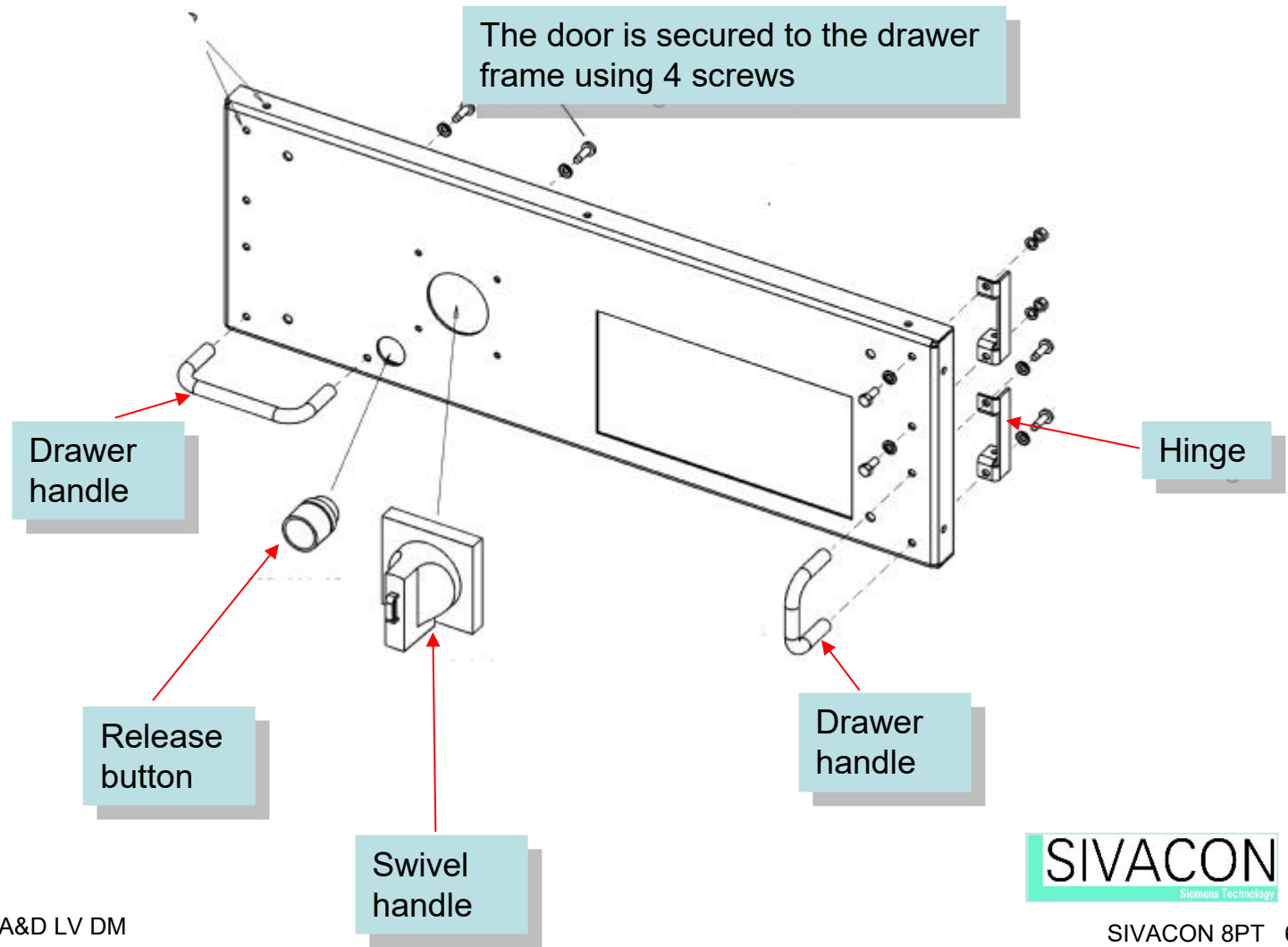

SIVACON 8PT Introduction

SIVACON 8PT Product design (extraction technology)



低压
控制与配电
动力配电中心

Low Voltage
Power Control
and Distribution
Power Distribution Center

www.siemens.com/lowvoltage

Drawer linkage

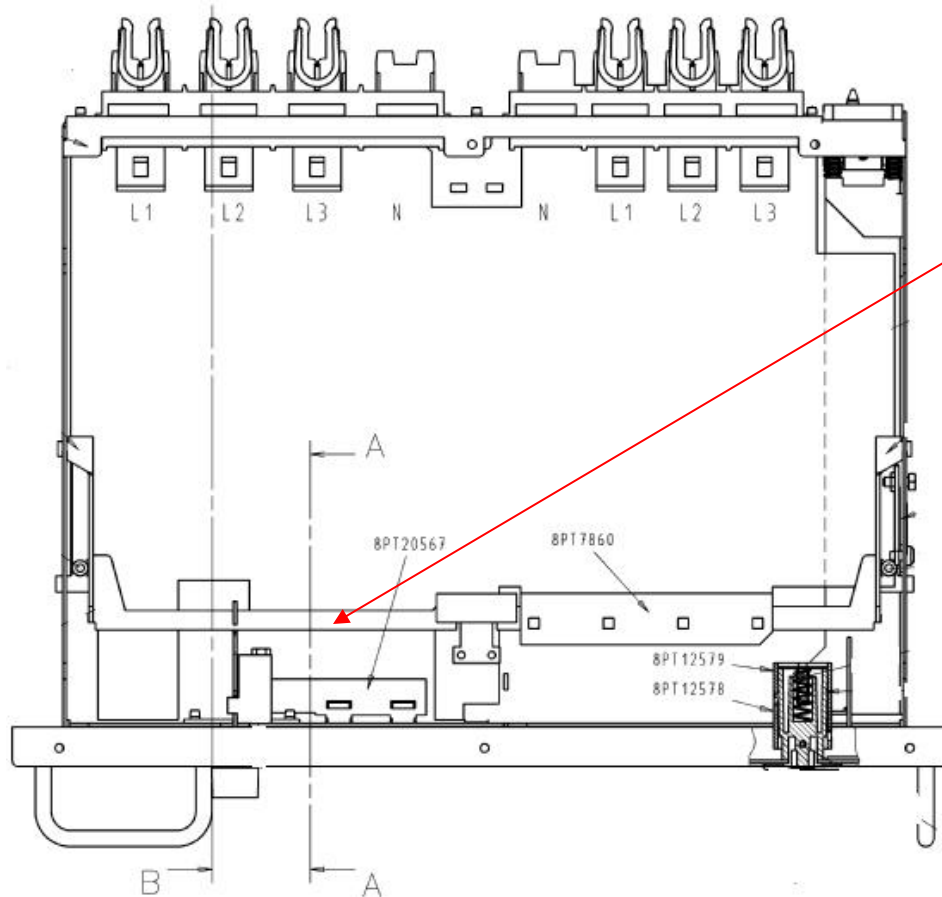

Position interlocking positioning mechanism

For connection, disconnection, test position selection and positioning



SIVACON 8PT Introduction

SIVACON 8PT Product design (extraction technology)



低压
控制与配电
动力配电中心

Low Voltage
Power Control
and Distribution
Power Distribution Center

www.siemens.com/lowvoltage

Drawer three position conversion

The drawer is in working condition

Breaker opening

Hold the release button

Move drawer to separate position

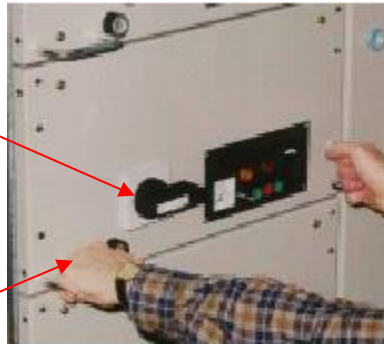

Less than 250A loop



Greater than or equal to 250A loop, with a labor-saving mechanism

Non-test position

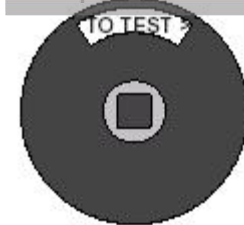

Note: The drawer cannot be moved after the second connection of the test position and the closing of the operating position

A&D LV DM



SIVACON 8PT Introduction

SIVACON 8PT Product design (extraction technology)



低压
控制与配电
动力配电中心

Low Voltage
Power Control
and Distribution
Power Distribution Center

www.siemens.com/lowvoltage

Drawer three position conversion

The drawer is in a separate state

Hold the release button

Move drawer to connection location

Breaker closing



Less than 250A loop

Non-test position



Greater than or equal to 250A loop, with a labor-saving mechanism



SIVACON 8PT Introduction

SIVACON 8PT Product design (extraction technology)



低压
控制与配电
动力配电中心

Low Voltage
Power Control
and Distribution
Power Distribution Center

www.siemens.com/lowvoltage

Drawer three position conversion

The drawers are separated

Hold the release button

Move drawer to test position

Rotational secondary propulsion mechanism to test state

The rotary secondary propulsion mechanism exits the test state

Hold the release button

Move the drawer to another location



Non-test position

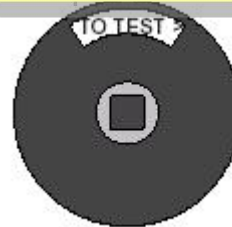

Test position

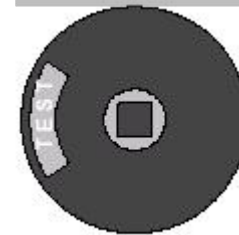

A&L



SIVACON 8PT Introduction

SIVACON 8PT Product design (extraction technology)



低压
控制与配电
动力配电中心

Low Voltage
Power Control
and Distribution
Power Distribution Center

www.siemens.com/lowvoltage

Vertical bus carrying capacity

Section	Rated current at different ambient temperatures I_n [A]						
	20°	25°	30°	35°	40°	45°	50°
Non-fume hood							
40x10	755	735	720	700	680	660	640
60x10	1075	1050	1025	1000	975	945	920
Fume hood body							
40x10	880	860	840	820	800	775	750
60x10	1260	1230	1200	1170	1140	1105	1075

Short-circuit strength

40X10: $I_{pk} = 125\text{kA}$, $I_{cw} = 50 \text{ kA}, 1\text{s}$

60X10: $I_{pk} = 163 \text{ kA}$ $I_{cw} = 65 \text{ kA}, 1\text{s}; 50 \text{ kA}, 3\text{s}$



SIVACON 8PT Introduction

SIVACON 8PT Product design (customer free design cabinet)



低压
控制与配电
动力配电中心

Low Voltage
Power Control
and Distribution
Power Distribution Center

www.siemens.com/lowvoltage

Product design

- ▶ Components can be freely selected
- ▶ Door with cabinet height or compartment with separate door
- ▶ Functional units can be separated separately
- ▶ The vertical distribution bus is optional with 3 or 4 poles
- ▶ Rated current up to 1200A
- ▶ Rated short-circuit strength

I_{pk}	up to 163 kA
I_{cw}	up to 65 kA



SIVACON 8PT Introduction

SIVACON 8PT Product design (Capacitance compensation cabinet)

低压
控制与配电
动力配电中心

Low Voltage
Power Control
and Distribution
Power Distribution Center

www.siemens.com/lowvoltage

Product design

- ▶ Non-choke type single unit up to 500kvar
- ▶ Choke type up to 350kvar
- ▶ Single capacitor modules up to 100kvar
- ▶ An electronic power factor automatic compensator mounted on the door is included in the control component
- ▶ Cabinet width 800mm



SIVACON
Siemens Technology

SIVACON 8PT Introduction
SIVACON 8PT 介绍



低压
控制与配电
动力配电中心

Low Voltage
Power Control
and Distribution
Power Distribution Center

www.siemens.com/lowvoltage

Thank you for
your attention!

